

CHAPTER 28

Exterior Wall Cladding—II (Masonry, Precast Concrete, and GFRC)

CHAPTER OUTLINE

- | | | | |
|-------------|--|--------------|--|
| 28.1 | ANCHORED MASONRY VENEER ASSEMBLY—GENERAL CONSIDERATIONS | 28.7 | CONNECTING THE PC CURTAIN WALL TO A STRUCTURE |
| 28.2 | BRICK VENEER WITH A CMU OR CONCRETE BACKUP WALL | 28.8 | BRICK AND STONE-FACED PC CURTAIN WALL |
| 28.3 | BRICK VENEER WITH A STEEL STUD BACKUP WALL | 28.9 | DETAILING A PC CURTAIN WALL |
| 28.4 | CMU BACKUP VERSUS STEEL STUD BACKUP | 28.10 | GLASS FIBER—REINFORCED CONCRETE (GFRC) CURTAIN WALL |
| 28.5 | AESTHETICS OF BRICK VENEER | 28.11 | FABRICATION OF GFRC PANELS |
| 28.6 | PRECAST CONCRETE (PC) CURTAIN WALL | 28.12 | DETAILING A GFRC CURTAIN WALL |

This is the first of the two chapters on exterior wall finishes; it includes masonry veneer, precast concrete, glass fiber–reinforced concrete (GFRC), and prefabricated masonry panels. Other exterior wall finishes—stucco, exterior insulation and finish systems (EIFS), stone cladding, and insulated metal panel walls—are discussed in the next chapter (Chapter 29).

ANCHORED MASONRY VENEER AND ADHERED MASONRY VENEER

Masonry veneer may either be (a) anchored masonry veneer or (b) adhered masonry veneer. In this chapter, only anchored masonry veneer is covered. Adhered masonry veneer is discussed in the following chapter because its detailing and construction process are similar to those of stucco.

28.1 ANCHORED MASONRY VENEER ASSEMBLY—GENERAL CONSIDERATIONS

Among all contemporary exterior wall cladding systems, masonry (brick, CMU, and stone) veneer is most widely used, and within the three masonry veneer systems, *brick veneer* is by far the most popular system. Its popularity lies in its durability, fire resistance, and aesthetic appeal. Additionally, the system requires almost no maintenance and can be used for buildings of all heights and complexity—from high-rise to low-rise and from simple rectilinear



CHAPTER 28
EXTERIOR WALL CLADDING—II
(MASONRY, PRECAST CONCRETE,
AND GFRG)

FIGURE 28.1 Because of its versatility, durability, economic advantages and aesthetic appeal, brick veneer is among the most commonly used facades for all types of buildings, particularly for mid-rise and high-rise buildings, as this New York City street shows. Seen in the background in this photo is the glass-clad Bloomberg Tower by Cesar Pelli and Associates with Schuman, Lichtenstein, Claman and Efron. (Photo by Marshall Gerometta of Emporis)

facades to intricate ones. A cursory survey of building facades in North American cities confirms this assertion, Figure 28.1.

A brick veneer generally consists of a single-wythe brick wall (generally 4 in. nominal thickness). The backup wall used with brick veneer may be load-bearing or non-load-bearing and may consist of one of the following:

- Wood or cold-formed steel stud
- Concrete masonry
- Reinforced concrete

A wood stud (or steel stud) load-bearing backup wall, Figure 28.2, is typically used in low-rise residential construction. Concrete masonry, non-load-bearing steel stud, and reinforced-concrete backup walls are generally used in commercial construction. In fact, brick veneer with concrete masonry backup is the wall assembly of choice for many building types, such as schools, university campus buildings, and offices.

The discussion presented here refers to brick veneer. It can, however, be extended to include other (CMU and stone) masonry veneers with little or no change.

ANCHORS

In a brick veneer assembly, the veneer is connected to the backup wall with steel anchors, which transfer the lateral load from the veneer to the backup wall. In this load transfer, the

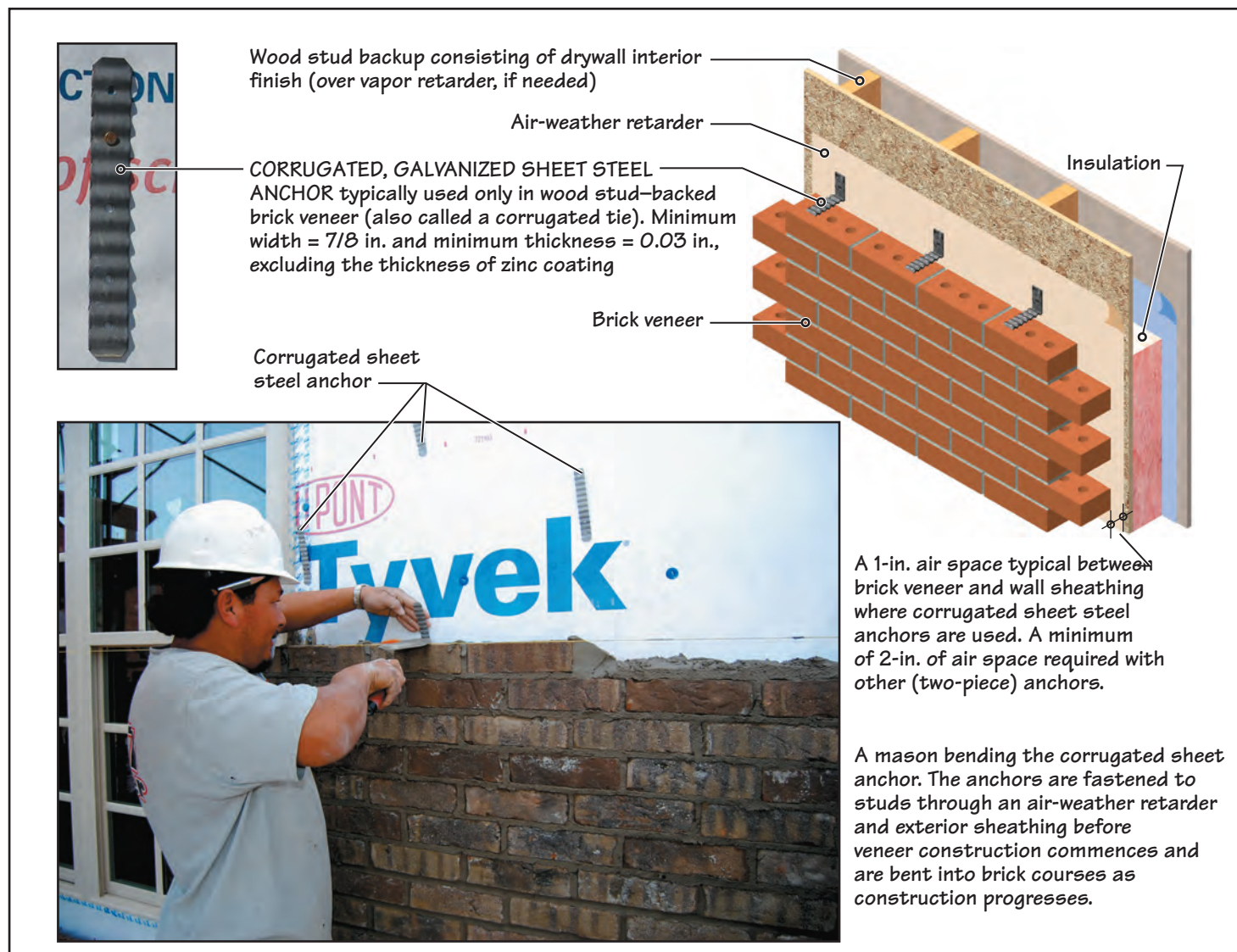

FIGURE 28.2 Brick veneer with a wood stud backup wall.

anchors are subjected to either axial compression or tension, depending on whether the wall is subjected to inward or outward pressure.

The anchors must, therefore, have sufficient rigidity and allow little or no movement in the plane perpendicular to the wall. However, because the veneer and the backup will usually expand or contract at different rates in their own planes, the design of anchors must accommodate upward-downward and side-to-side movement, Figure 28.3.

Anchors for a brick veneer wall assembly are, therefore, made of two pieces that engage each other. One piece is secured to the backup, and the other is embedded in the horizontal mortar joints of the veneer. An adjustable two-piece anchor should allow the veneer to move with respect to the backup in the plane of the wall but not perpendicular to it.

An exception to this requirement is a one-piece sheet steel corrugated anchor (Figure 28.2). The corrugations in the anchor enhance the bond between the anchor and the mortar, increasing the anchor's pullout strength. But the corrugations weaken the anchor in compression by making it more prone to buckling. A one-piece corrugated anchor is recommended for use only in low-rise, wood light-frame buildings in low-wind and low-seismic-risk locations.

Galvanized steel is commonly used for anchors, but stainless steel is recommended where durability is an important consideration and/or where the environment is unusually corrosive.

The spacing of anchors should be calculated based on the lateral load and the strength of the anchor. However, the maximum spacing for a one-piece corrugated anchor or an adjustable two-piece wire anchor (wire size W1.7) is limited by the codes to one anchor for every 2.67 ft² [28.1]. Additionally, the anchors should not be spaced more than 32 in. on center horizontally and not more than 18 in. vertically, Figure 28.4.

CHAPTER 28

EXTERIOR WALL CLADDING—II
(MASONRY, PRECAST CONCRETE,
AND GFRG)

FIGURE 28.3 Adjustability requirements in various directions of a two-piece anchor.

AIR SPACE

An air space of 2 in. (clear) is recommended for brick veneer. Thus, if there is $1\frac{1}{2}$ -in.-thick (rigid) insulation between the backup wall and the veneer, the backup and the veneer must be spaced $3\frac{1}{2}$ in. apart so that the air space is 2 in. clear, Figure 28.5.

In a narrower air space, there is a possibility that if the mortar squeezes out into the air space during brick laying, it may bridge over and make a permanent contact with the backup wall. A 2-in. air space reduces this possibility. In a wood-stud-backed wall assembly with one-piece corrugated anchors, however, a 1-in. air space is commonly used (Figure 28.2).

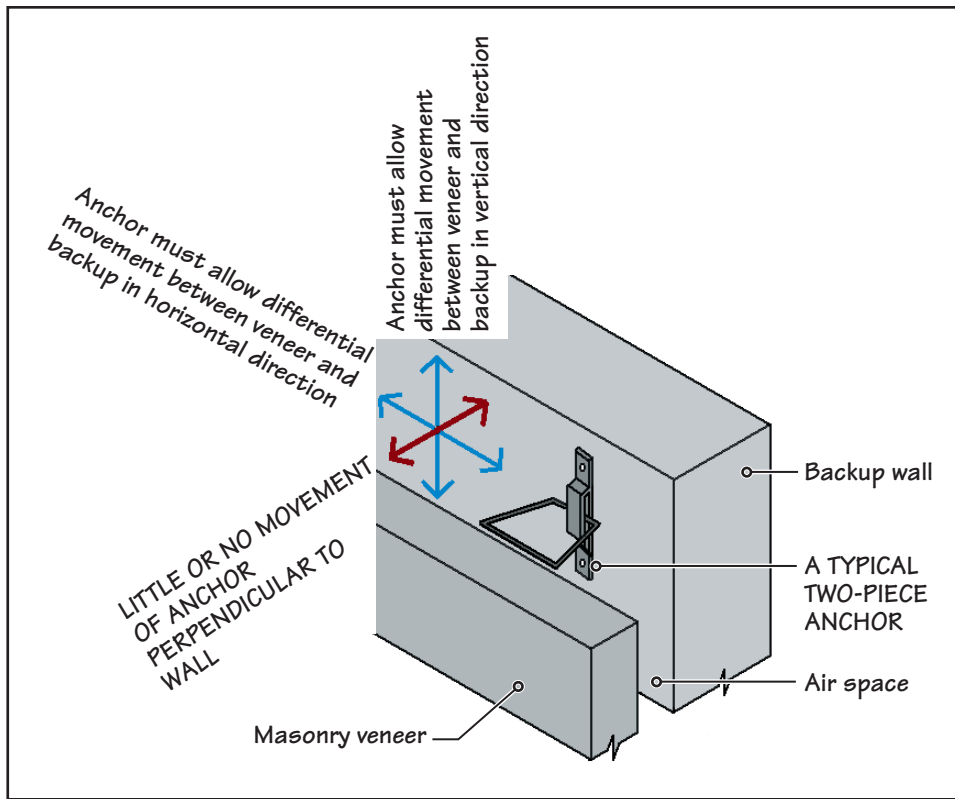
The maximum distance between the veneer and the backup wall is limited by the masonry code to $4\frac{1}{2}$ in. unless the anchors are specifically engineered to withstand the compressive forces imposed on them by the lateral load. With a large gap between the veneer and the backup wall, the anchors are more prone to buckling failure.

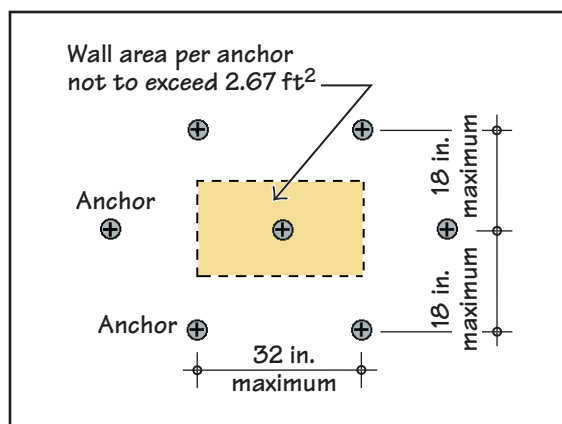

FIGURE 28.4 Anchor spacing should be determined based on the lateral load and the strength of anchors. However, for a one-piece corrugated sheet anchor or a two-piece adjustable wire anchor (wire size W1.7), the maximum spacing allowed is as shown. W1.7 means that the cross-sectional area of wire = 0.017 in.^2 (see Section 21.13). Anchors should preferably be staggered, as shown.

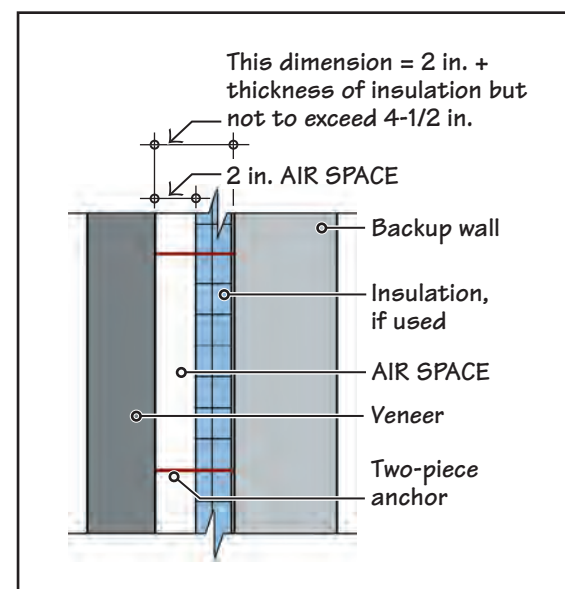

FIGURE 28.5 A minimum air space of 2 in. is required except in low-rise buildings, where a 1-in. air space is common. The gap between the veneer and the backup wall should not exceed $4\frac{1}{2}$ in.

NOTE

Brick Ledge

A brick ledge is the depression in the concrete foundation at the base of brick veneer and is generally 1½ in. deep, because it is formed by 2-by lumber used as a block-out when placing concrete (Figure 28.6). The depression further prevents water intrusion into the backup wall.

SUPPORT FOR BRICK VENEER—SHELF ANGLES ANCHORED TO STRUCTURAL FRAME

The dead load of brick veneer may be borne by the wall foundation without any support at intermediate floors up to a maximum height of 30 ft above ground. Uninterrupted foundation-supported veneer is commonly used in one- to three-story wood or cold-formed steel-frame buildings, Figure 28.6(a). In these buildings, the air space is continuous from the foundation to the roof level, and the entire load of the veneer bears on the foundation. A 1½-in. depression, referred to as the *brick ledge*, is commonly created in the foundation to receive the first course of the veneer.

In mid- and high-rise buildings, the veneer is generally supported at each floor using (preferably hot-dip galvanized) steel *shelf angles* (also referred to as *relieving angles*). Shelf angles are supported by, and anchored to, the building's structure. In a frame structure, the shelf angles are anchored (welded or bolted) to the spandrel beams, Figure 28.6(b). In a load-bearing wall structure, the shelf angles are anchored to the exterior walls. The details of the anchorage of a shelf angle to the structure are given later in the chapter.

A gap should be provided between the top of the veneer and the bottom of the shelf angle. This gap accounts for the vertical expansion of brick veneer (after construction) and the deflection of the spandrel beam under live load changes, and must be determined by the architect in consultation with the structural engineer. The gap should be treated with a

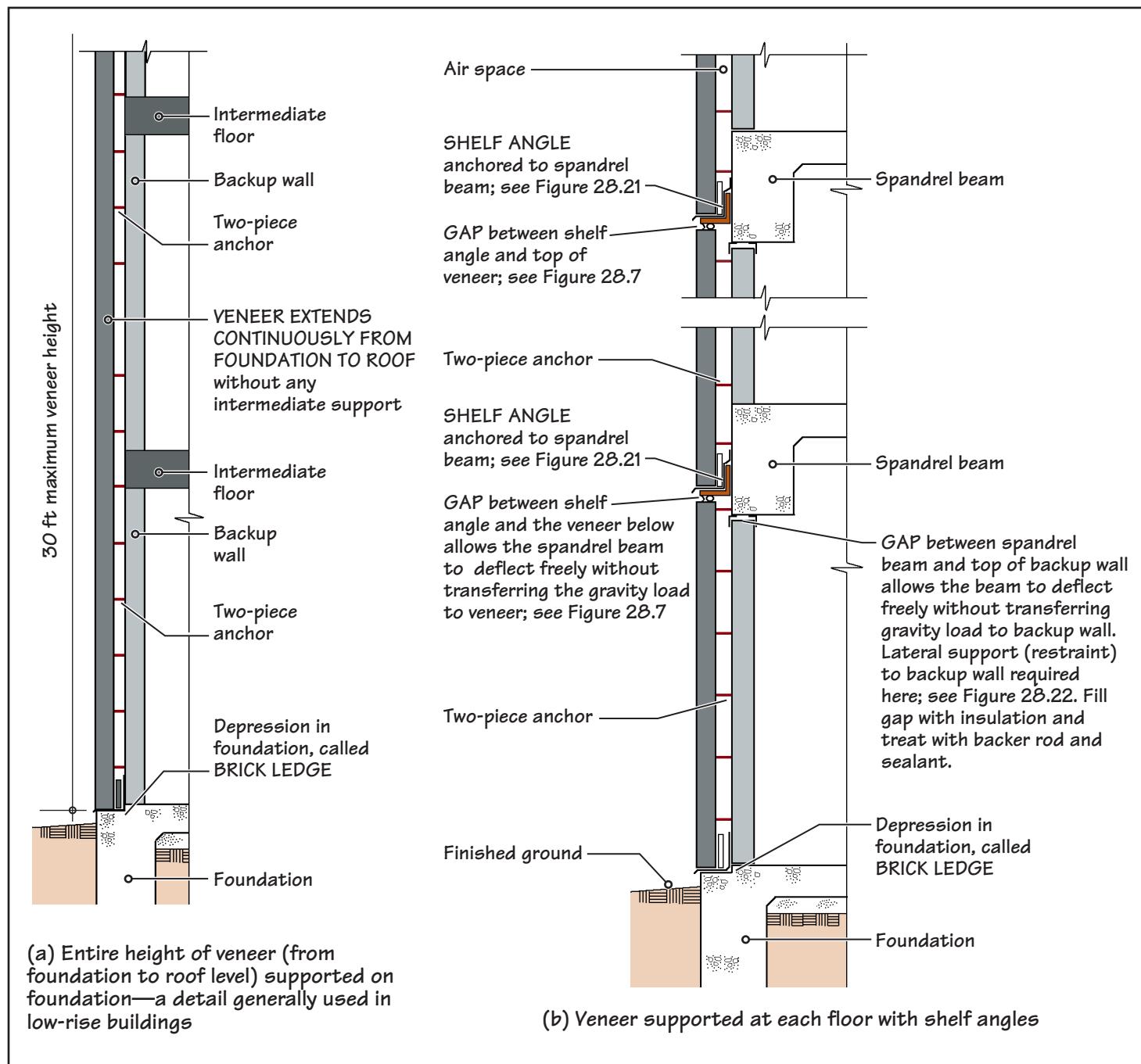

FIGURE 28.6 Dead load support for veneer.

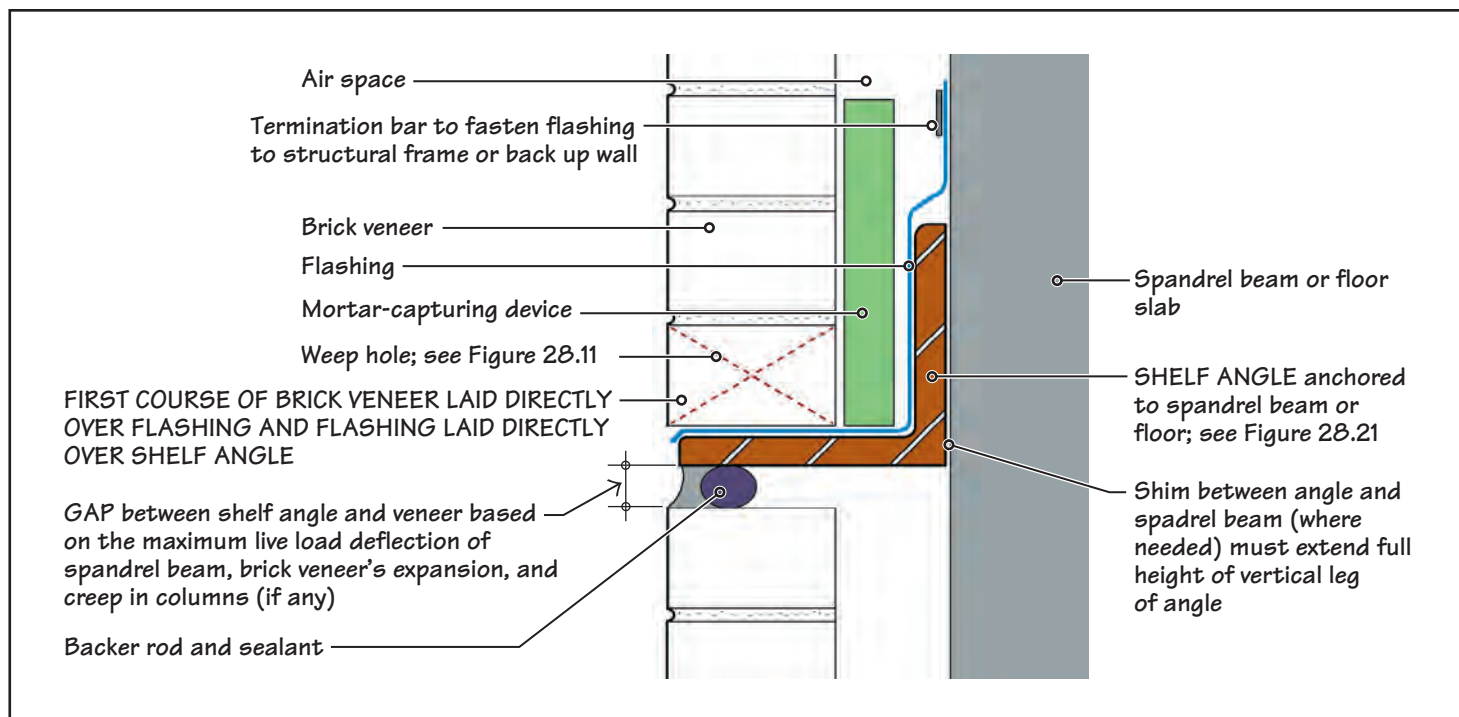

FIGURE 28.7 Schematic detail at a typical shelf angle.

backer rod and sealant, Figure 28.7. The veneer may project beyond the shelf angle, but the projection should not exceed one-third of the thickness of the veneer.

Shelf angles must not be continuous. A maximum length of about 20 ft is used for shelf angles, with nearly a $\frac{3}{8}$ -in. gap between adjacent lengths to provide for thermal movement. The gap should ideally be at the same location as the vertical expansion joints in the veneer.

LINTEL ANGLES—LOOSE-LAID

Whether the veneer is supported entirely on the foundation or at each floor, additional dead load support for the veneer is needed over wall openings. The lintels generally used over an opening in brick veneer are of steel (preferably hot-dip galvanized) angles, Figure 28.8. Unlike the shelf angles, lintel angles are not anchored to the building's structural frame but are simply placed (loose) on the veneer, Figure 28.9.

To allow the lintel to move horizontally relative to the brick veneer, no mortar should be placed between the lintel bearing and the brick veneer. Flashing and weep holes must be provided over lintels in exactly the same way as on the shelf angles.

LOCATIONS OF FLASHINGS AND END DAMS

As shown in Figure 28.8, flashings must be provided at all interruptions in the brick veneer:

- At the foundation level
- Over a shelf angle
- Over a lintel angle
- Under a window sill

Joints between flashings must be sealed, and all flashings must be accompanied by weep holes. The flashing should preferably project out of the veneer face to ensure that the water will drain to the outside of the veneer (Figure 28.7). Where the flashing terminates, it must be turned up (equal to the height of one brick) to form a dam to prevent water from entering the air space, Figure 28.10.

FLASHING MATERIALS

Flashing material must be impervious to water and resistant to puncture, tearing, and abrasion. Additionally, flashing must be flexible so that it can be bent to the required profile. Durability is also important because replacing failed flashing is cumbersome and expensive. Therefore, metal flashing must be corrosion resistant. Resistance to ultraviolet

PART 2
MATERIALS AND SYSTEMS
OF CONSTRUCTION

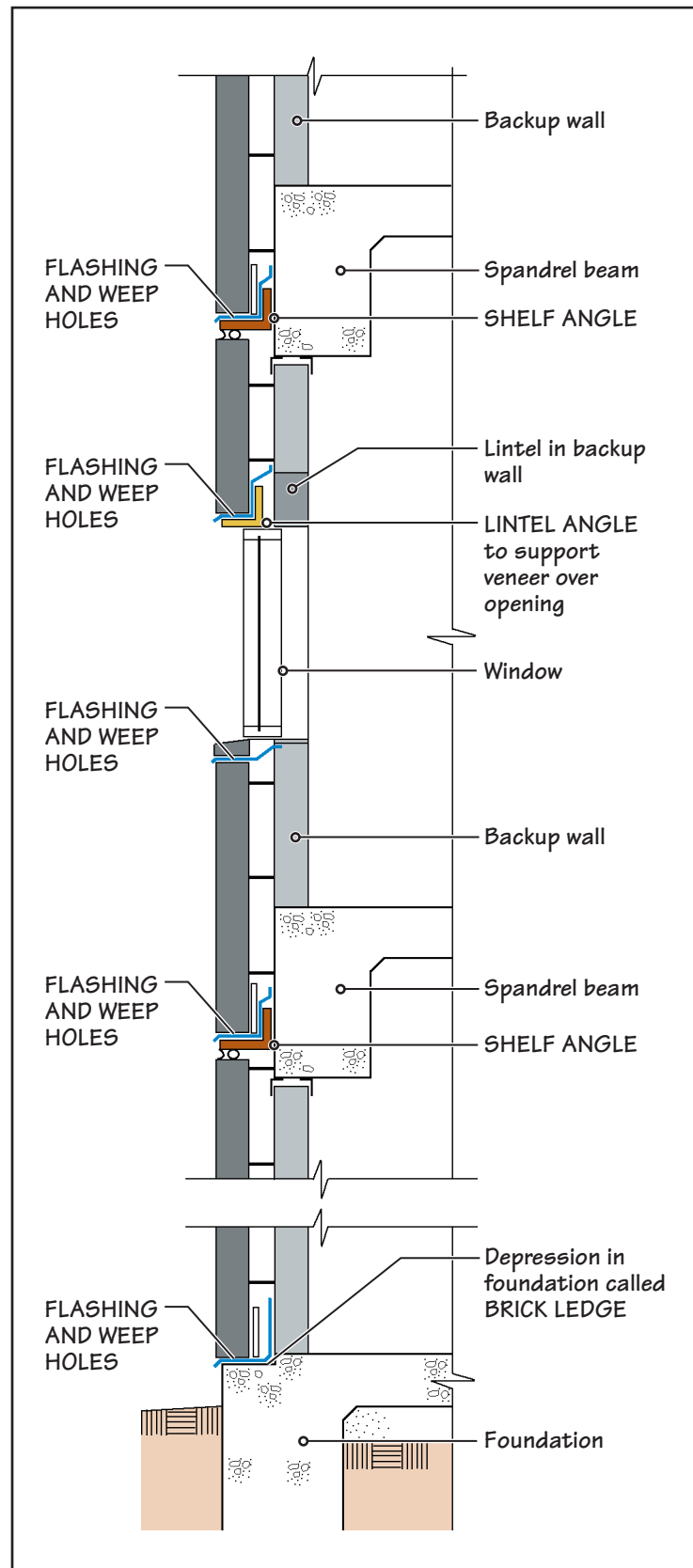

FIGURE 28.8 A schematic section showing the locations of shelf angles, lintel angles, and flashings in a typical brick veneer assembly.

CHAPTER 28
EXTERIOR WALL CLADDING—II
(MASONRY, PRECAST CONCRETE,
AND GFRG)

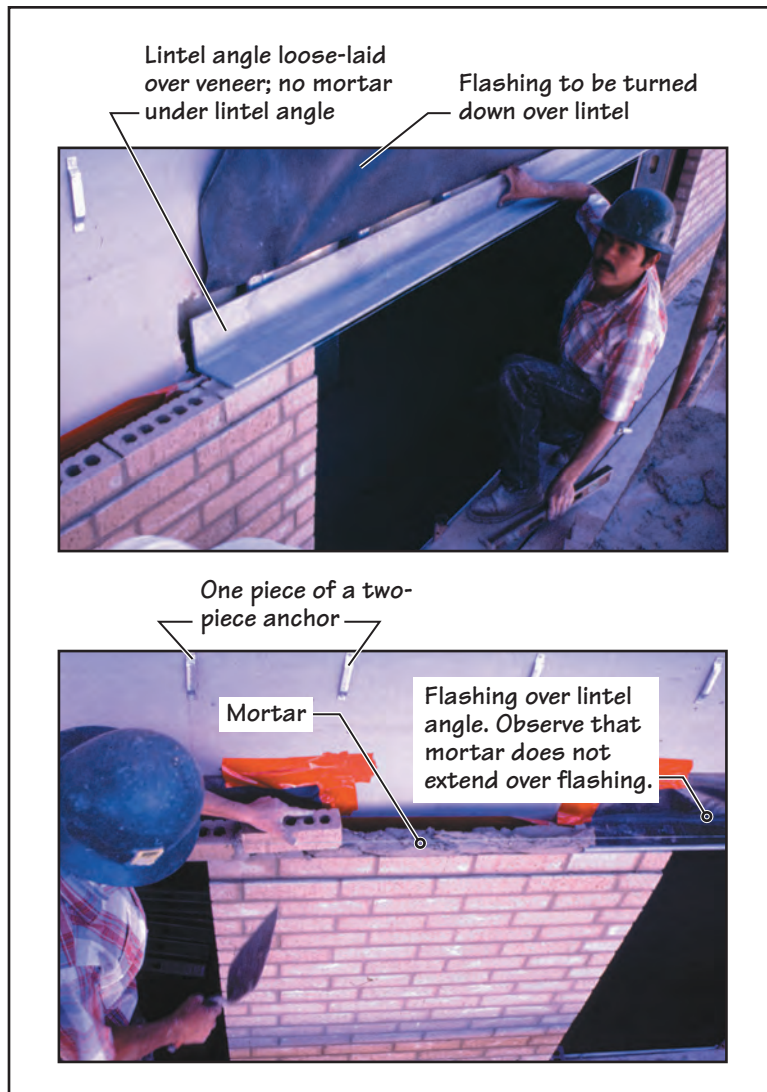
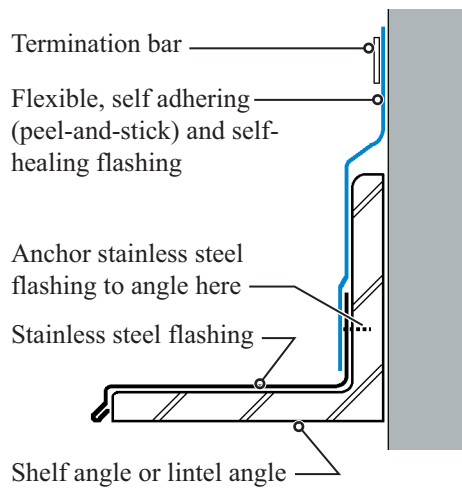

FIGURE 28.9 Lintel angles in a brick veneer wall. Note that the first course of veneer over flashing is laid without any mortar bed between the bricks and flashing; see also Figure 28.7.



FIGURE 28.10 End dams in flashing, revealed by removing a few bricks of the window sill (in the rowlock course). Weep holes in the brick sill (over the flashing) are not shown for clarity.

PART 2
MATERIALS AND SYSTEMS
OF CONSTRUCTION



radiation is also necessary because the projecting part of the flashing is exposed to the sun. Commonly used flashing materials are as follows:

- Stainless sheet steel
- Copper sheet
- Plastics such as
 - Polyvinyl chloride (PVC)
 - Neoprene
 - Ethylene propylene diene monomer (EPDM)
- Composite flashing consisting of
 - Rubberized asphalt with cross-laminated polyethylene, typically available as self-adhering and self-healing flashing
 - Copper sheet laminated on both sides to asphalt-saturated paper or fiberglass felt

Copper and stainless steel are among the most durable flashing materials. Copper's advantage over stainless steel is its greater flexibility, which allows it to be bent to shape more easily. However, copper will stain light-colored masonry because of its corrosion, which yields a greenish protective cover (patina). Copper combination flashing, consisting of a copper sheet laminated to asphalt-saturated paper, reduces its staining potential.

A fairly successful flashing is a two-part flashing comprising a self-adhering, self-healing polymeric membrane and a stainless steel drip edge. The durability and rigidity of stainless steel makes a good drip edge, and the flexible, self-adhering membrane simplifies flashing installation.

NOTE

Weep Hole Spacing

A center-to-center spacing of 24 in. is generally used for weep holes when open-head joints are used. A spacing of 16 in. is used with weep holes consisting of wicks or tubes.

CONSTRUCTION AND SPACING OF WEEP HOLES

Weep holes must be provided immediately above the flashing. There are several different ways to provide weep holes. The simplest and most effective weep hole is an open vertical mortar joint (open-head joint) in the veneer, Figure 28.11.

To prevent insects and debris from lodging in the open-head joint, joint screens may be used. A joint screen is an L-shaped sheet metal or plastic element, Figure 28.12(a). Its vertical leg has louvered openings to let the water out, and the horizontal leg is embedded in the horizontal mortar joint of the veneer. The joint screen has the same width as the head joints. An alternative honeycombed plastic joint screen is also available, Figure 28.12(b).

Instead of the open-head joint, wicks or plastic tubes ($\frac{3}{8}$ -in. diameter) may be used in a mortared-head joint. Wicks, which consist of cotton ropes, are embedded in head joints,

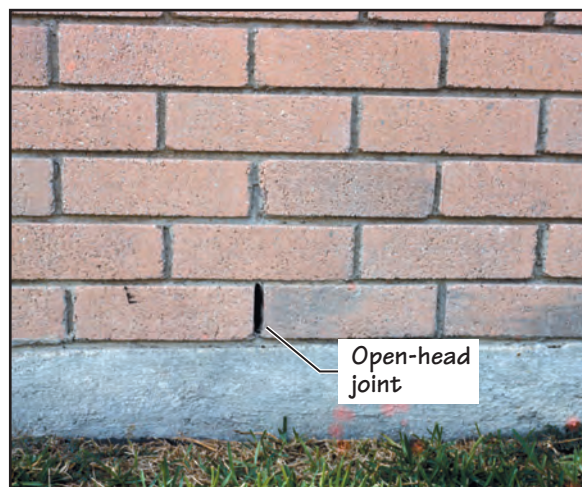

FIGURE 28.11 Open-head joints as weep holes.

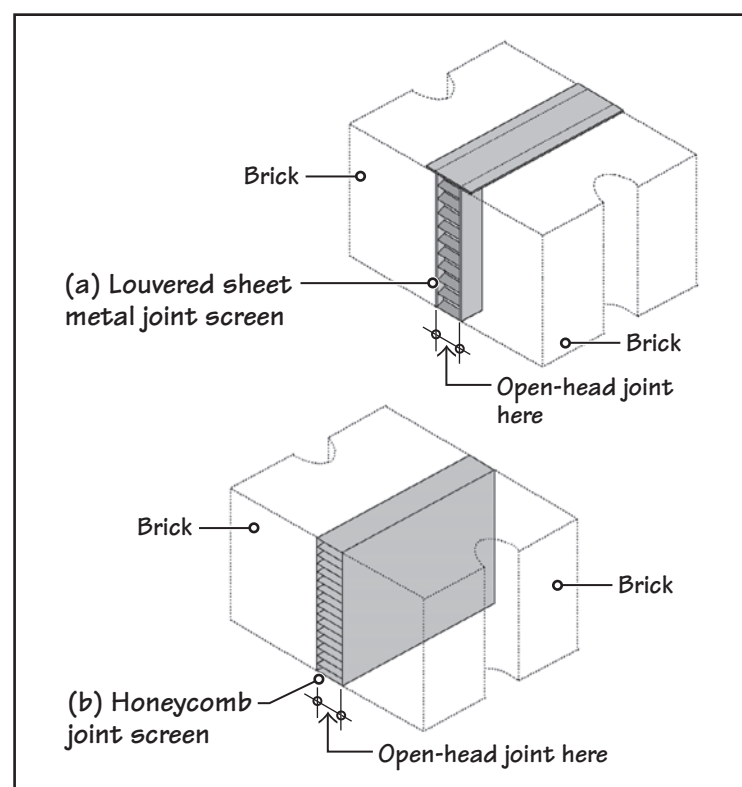

FIGURE 28.12 Two alternative screens used with weep holes consisting of open-head joints.

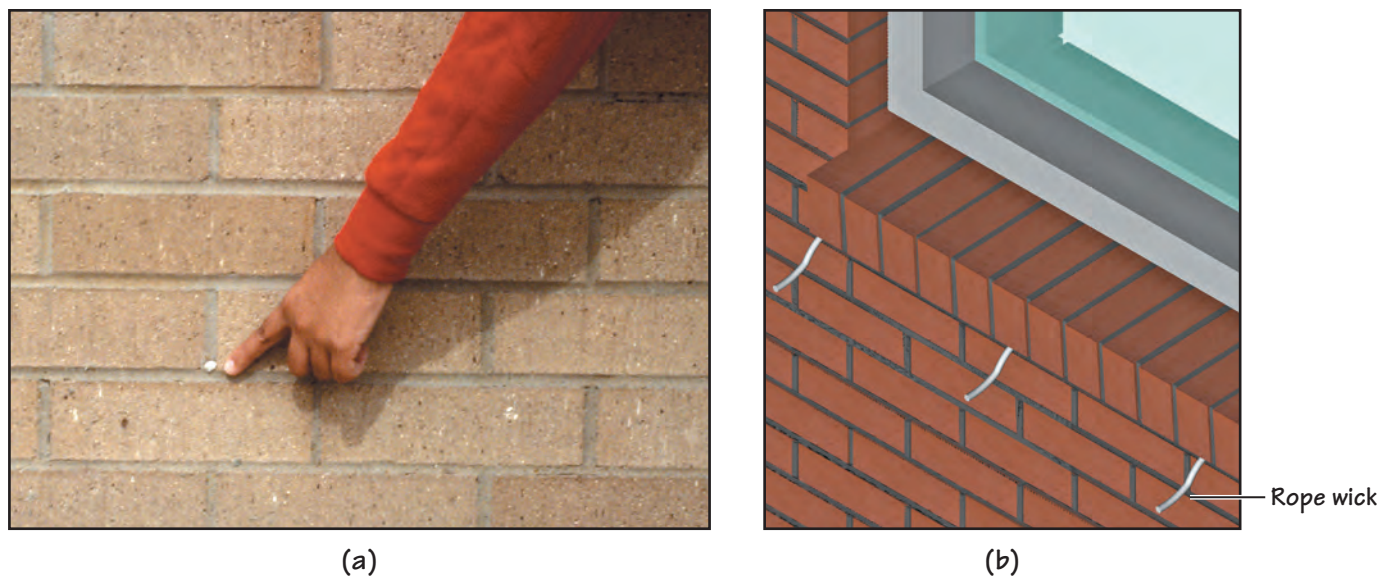

FIGURE 28.13 (a) Wicks as weep holes. (b) The wick ropes will be trimmed similar to those shown in (a).

Figure 28.13. They absorb water from the air space by capillary action and drain it to the outside. Their drainage efficiency is low.

Plastic tubes are better than wicks, but they do not function as well as open-head joints. They are placed in head joints with a rope inside each tube. The ropes are pulled out after the veneer has been constructed. This ensures that the air spaces of the tubes are not clogged by mortar droppings.

A sufficient number of weep holes must be provided for the drainage of the air space. Generally, a weep hole spacing of 24 in. is used with open-head joints; 16-in. spacing is used with wicks or tubes.

MORTAR DROPPINGS IN THE AIR SPACE— MORTAR-CAPTURING DEVICE

For the air space to function as an effective drainage layer, it is important to minimize mortar droppings in the air space. Excessive buildup of mortar in the air space bridges the space. Additionally, the weep holes function well only if they are not clogged by mortar droppings. Poor bricklaying practice can result in substantial accumulations of mortar on the flashing. Care in bricklaying to reduce mortar droppings is therefore essential.

Additional measures must also be incorporated to keep the air space unclogged. An earlier practice was to use a 2-in.-thick bed of pea gravel over the flashing. This provides a drainage bed that allows the water to percolate to the weep holes.

A better alternative is to use a *mortar-capturing device* in the air space immediately above the flashing. This device consists of a mesh made of polymeric strands, which trap the droppings and suspend them permanently above the weep holes, Figure 28.14. The use of a mortar-capturing device allows water in the air space to percolate freely through mortar droppings to reach the weep holes.

CONTINUOUS VERTICAL EXPANSION JOINTS IN BRICK VENEER

As stated in Section 9.8, brick walls expand after construction. Therefore, a brick veneer must be provided with continuous vertical expansion joints at intervals, Figure 28.15.

The maximum recommended spacing for vertical expansion joints is 25 ft in the field of the wall and not more than 10 ft from the wall's corner [28.2]. The joints are detailed so that sealant and backer rods replace mortar joints for the entire length of the continuous vertical expansion joint, allowing the bricks on both sides of the joint to move while maintaining a waterproof seal, Figure 28.16. The width of the expansion joint is $\frac{1}{2}$ in. (minimum) to match the width of the mortar joints.

With vertical expansion joints and the gaps under shelf angles (which function as horizontal expansion joints), a brick veneer essentially consists of individual brick panels that can expand and contract horizontally and vertically without stressing the backup wall or the building's structure.

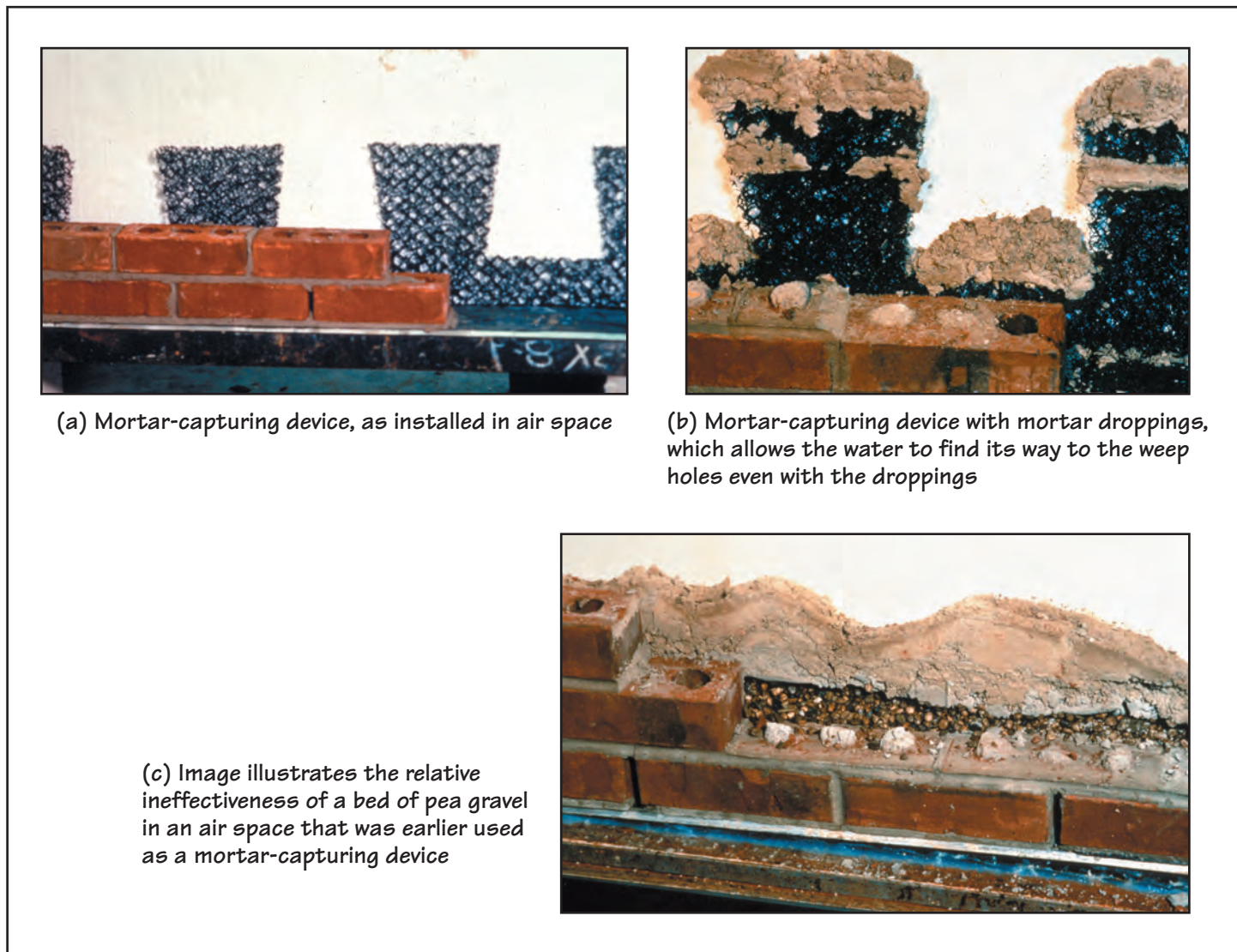

FIGURE 28.14 Mortar-capturing device. (Photos courtesy of Mortar Net USA Ltd., producers of The Mortar Net™)

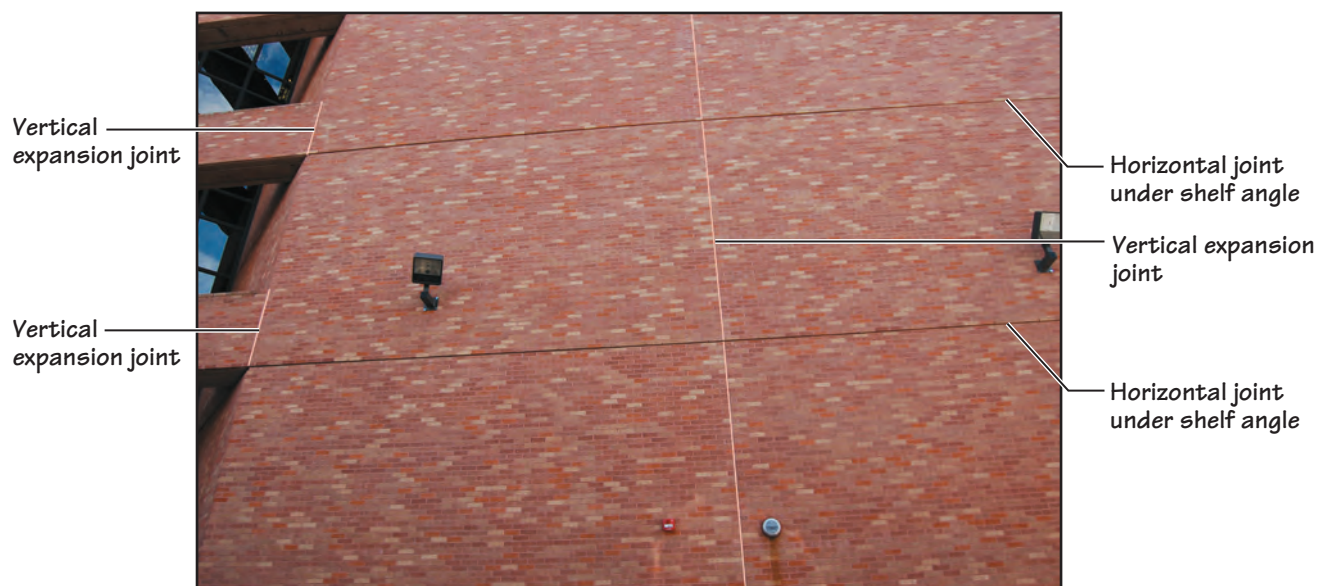

FIGURE 28.15 Continuous vertical expansion joints in brick veneer. Also note the continuous horizontal joints under the shelf angles.

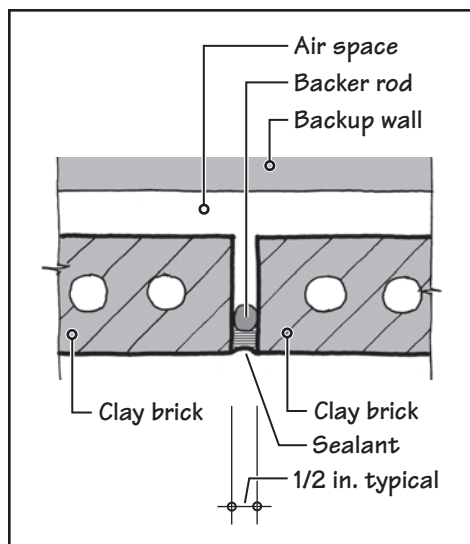

FIGURE 28.16 Detail plan of a vertical expansion joint in brick veneer. This illustration is the same as Figure 9.17.

CHAPTER 28
EXTERIOR WALL CLADDING—II
(MASONRY, PRECAST CONCRETE,
AND GFRC)

MORTAR TYPE AND MORTAR JOINT PROFILE

Type N mortar is generally specified in all-brick veneer except in seismic zones, where Type S mortar may be used (see Section 24.2). A concave joint profile yields veneer with more water resistance (see Section 24.3).

PRACTICE QUIZ

Each question has only one correct answer. Select the choice that best answers the question.

- The backup wall in a brick veneer wall assembly consists of a
 - reinforced-concrete wall.
 - CMU wall.
 - wood or steel stud wall.
 - all of the above.
 - (b) and (c) only.
- In a brick veneer wall assembly, the wind loads are transferred directly from the veneer to the building's structure.
 - True
 - False
- The anchors used to anchor the brick veneer to the backup wall are generally two-piece anchors to allow differential movement between the veneer and the backup
 - in all three principal directions.
 - perpendicular to the plane of the veneer.
 - within the plane of the veneer.
 - none of the above.
- The anchors in a brick veneer wall assembly provide
 - gravity load support to both veneer and backup.
 - lateral load support to both veneer and backup.
 - gravity load support to the veneer.
 - lateral load support to the veneer.
- The minimum required width of the air space between a brick veneer and a CMU backup wall is
 - 1 in.
 - $1\frac{1}{2}$ in.
 - 2 in.
 - 3 in.
 - none of the above.
- The minimum width of the air space generally used between a brick veneer and a wood stud backup wall is
 - 1 in.
 - $1\frac{1}{2}$ in.
 - 2 in.
 - $2\frac{1}{2}$ in.
 - 3 in.
- A steel angle used to support the weight of a brick veneer over an opening is called a
 - lintel angle.
 - shelf angle.
 - relieving angle.
 - all of the above.
 - (a) or (b).
- A shelf angle must be anchored to the building's structural frame.
 - True
 - False
- A lintel angle must be anchored to the building's structural frame.
 - True
 - False
- In a multistory building, shelf angles are typically used at
 - each floor level.
 - each floor level and at midheight between floors.
 - at the foundation level.
 - all of the above.
 - (a) and (c).
- For a brick veneer that bears on the foundation and continues to the top of the building without any intermediate support, the maximum veneer height is limited to
 - 40 ft.
 - 35 ft.
 - 30 ft.
 - 25 ft.
 - 20 ft.
- A shelf angle in a brick veneer assembly must provide
 - gravity load support to the veneer.
 - lateral load support to the veneer.
 - gravity load support to both veneer and backup.
 - lateral load support to both veneer and backup.
- In a brick veneer assembly, flashing is required
 - at the foundation level.
 - over a lintel angle.
 - over a shelf angle.
 - under a window sill.
 - all of the above.
- In a brick veneer assembly, weep holes are required at
 - each floor level.
 - each alternate floor level.
 - immediately above the flashing.
 - immediately below the flashing.
 - 2 in. above a flashing.
- The most efficient weep hole in a brick veneer consists of a
 - wick.
 - plastic tube.
 - open-head joint.
 - None of the above.
- A mortar-capturing device in a brick veneer assembly is used
 - at each floor level.
 - at each alternate floor level.
 - immediately above a flashing.
 - immediately below a flashing.
 - 2 in. above a flashing.
- In a brick veneer assembly, vertical expansion joints should be provided at a maximum distance of
 - 40 ft in the field of the wall and 40 ft from a wall's corner.
 - 30 ft in the field of the wall and 30 ft from a wall's corner.
 - 30 ft in the field of the wall and 20 ft from a wall's corner.
 - 25 ft in the field of the wall and 10 ft from a wall's corner.

28.2 BRICK VENEER WITH A CMU OR CONCRETE BACKUP WALL

Figure 28.17 shows an overall view of a brick veneer wall assembly with a CMU backup wall. The steel anchors that connect the veneer to the CMU backup wall are two-piece wire anchors. One piece is part of the joint reinforcement embedded in the CMU walls, Figure 28.18(a). The other piece fits into this piece and is embedded in the veneer's bed joint.

Several other types of anchors used with a CMU backup wall are available, such as that shown in Figure 28.18(b). Figure 28.18(c) shows a typical anchor used with a reinforced-concrete member (spandrel beam or backup wall).

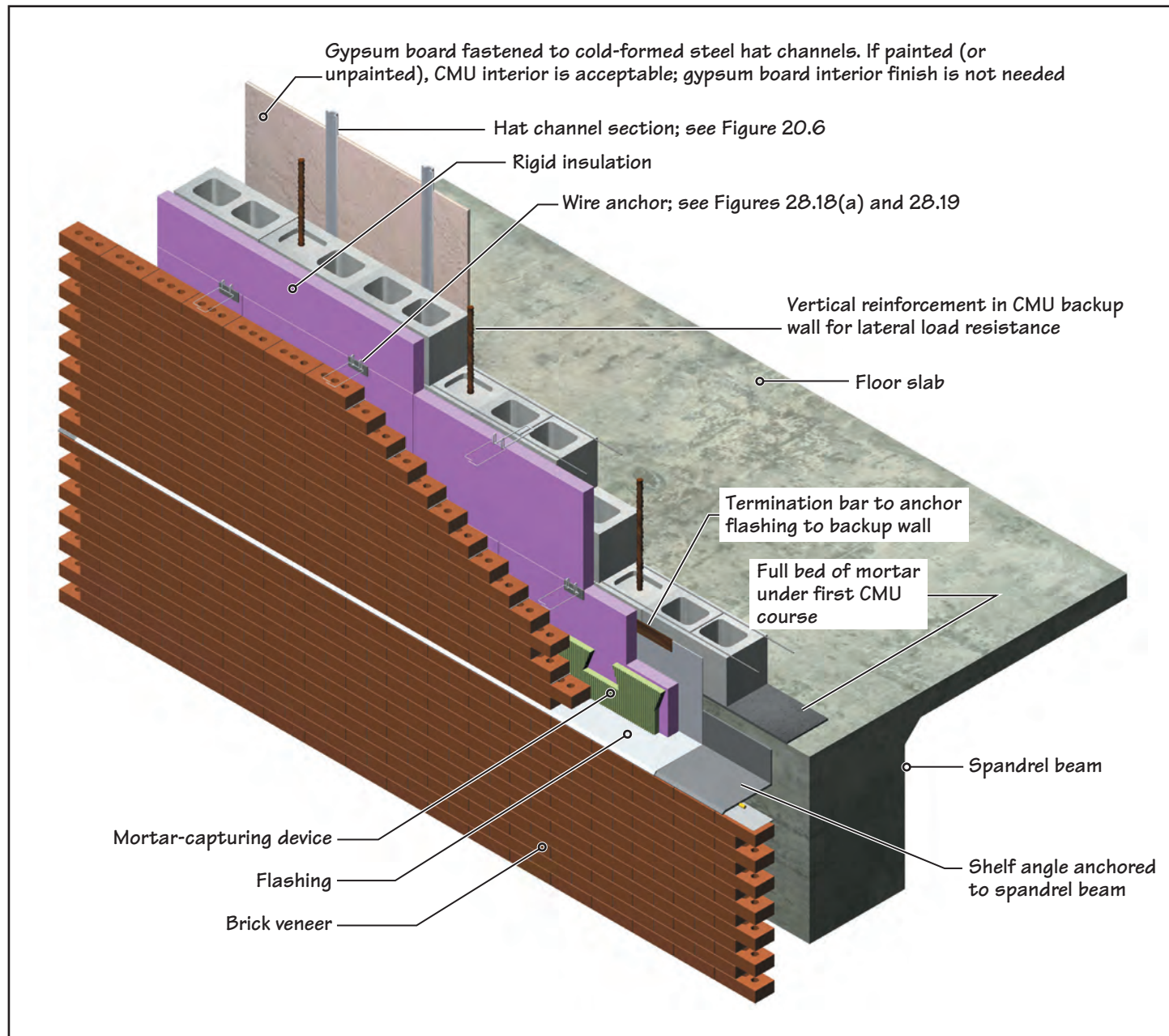

FIGURE 28.17 Brick veneer with CMU backup wall.

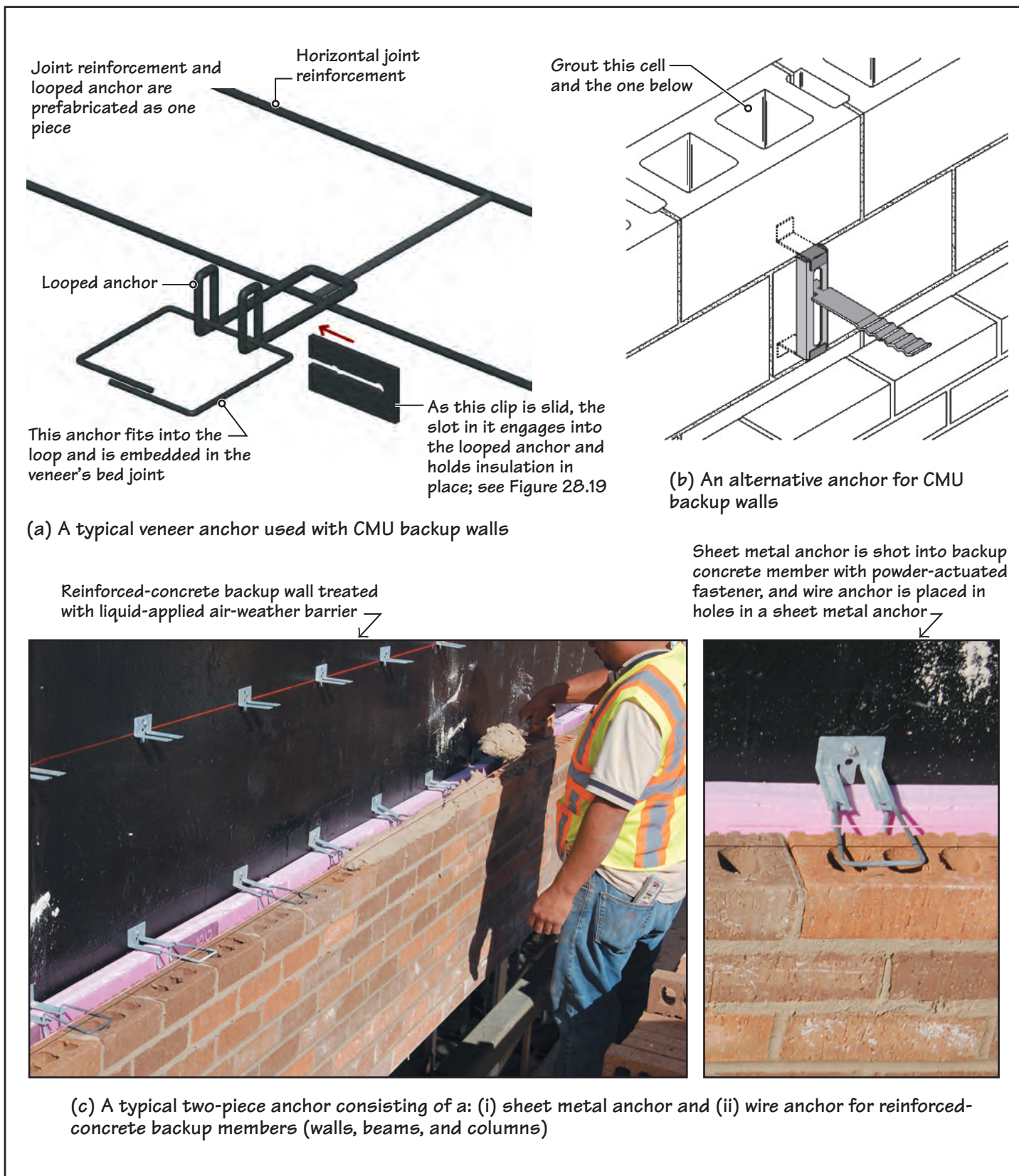

FIGURE 28.18 Typical anchors used with CMU and concrete backup walls.

PART 2
MATERIALS AND SYSTEMS
OF CONSTRUCTION

In seismic regions, the use of seismic clips is recommended. A seismic clip engages a continuous wire reinforcement in brick veneer. Both the seismic clip and the wire are embedded in the veneer's bed joint. A typical seismic clip is shown in Figure 28.19. Figures 28.20 to 28.22 show important details of brick veneer construction and a CMU backup wall.

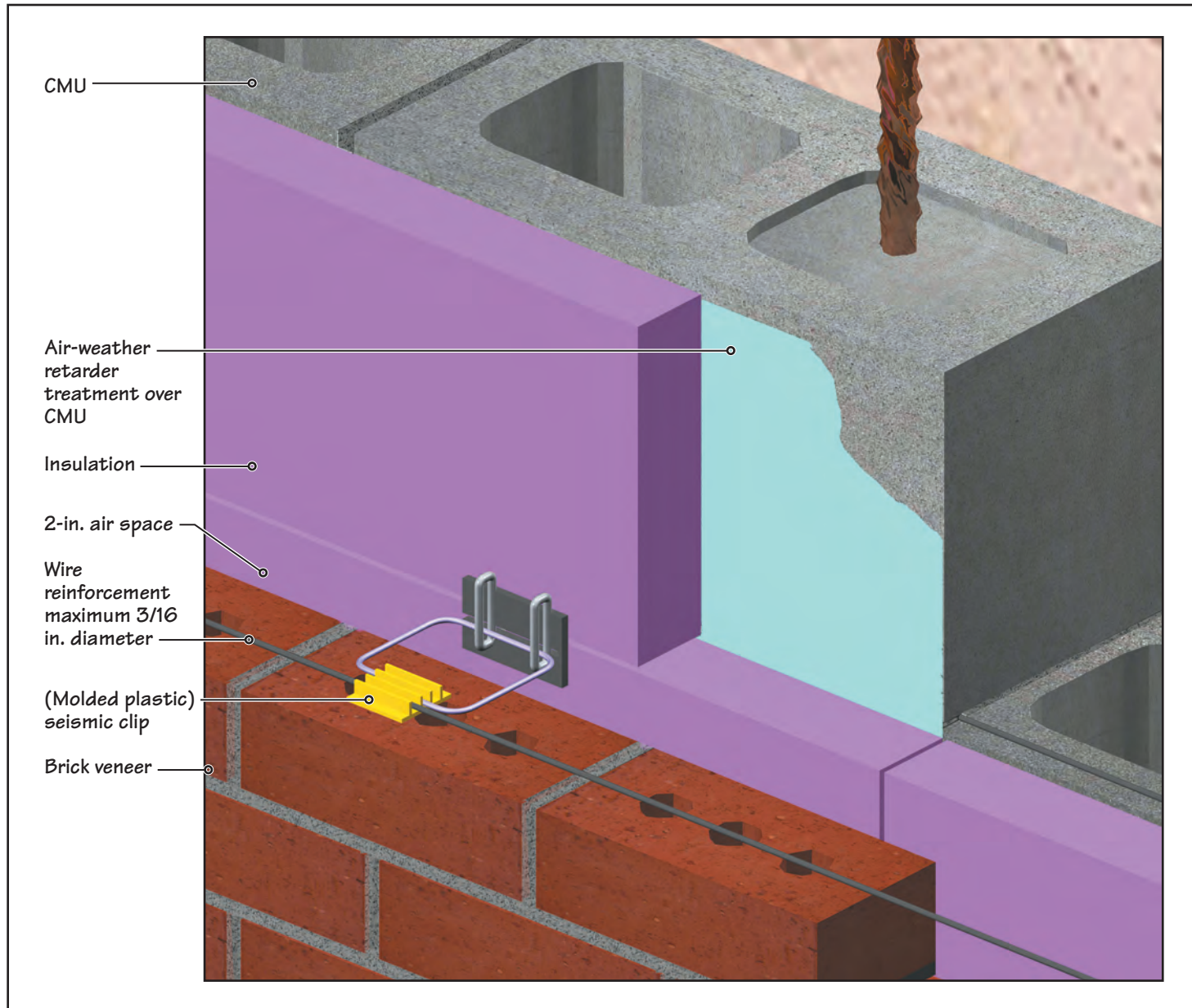

FIGURE 28.19 A typical seismic clip in brick veneer. The clip is embedded in the mortar along with wire reinforcement.

CHAPTER 28
EXTERIOR WALL CLADDING—II
(MASONRY, PRECAST CONCRETE,
AND GFRG)

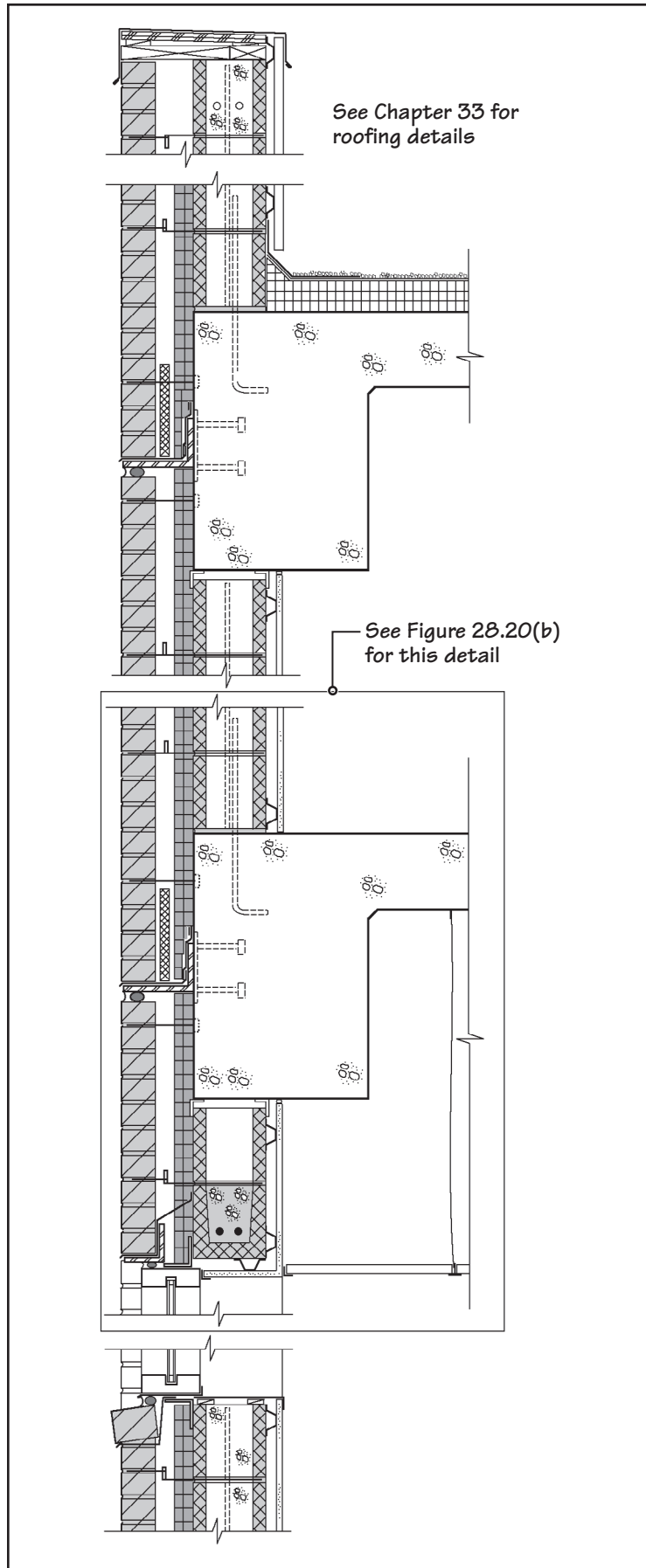

FIGURE 28.20 (a) A wall section through a typical multistory reinforced-concrete building with brick veneer and CMU backup wall.

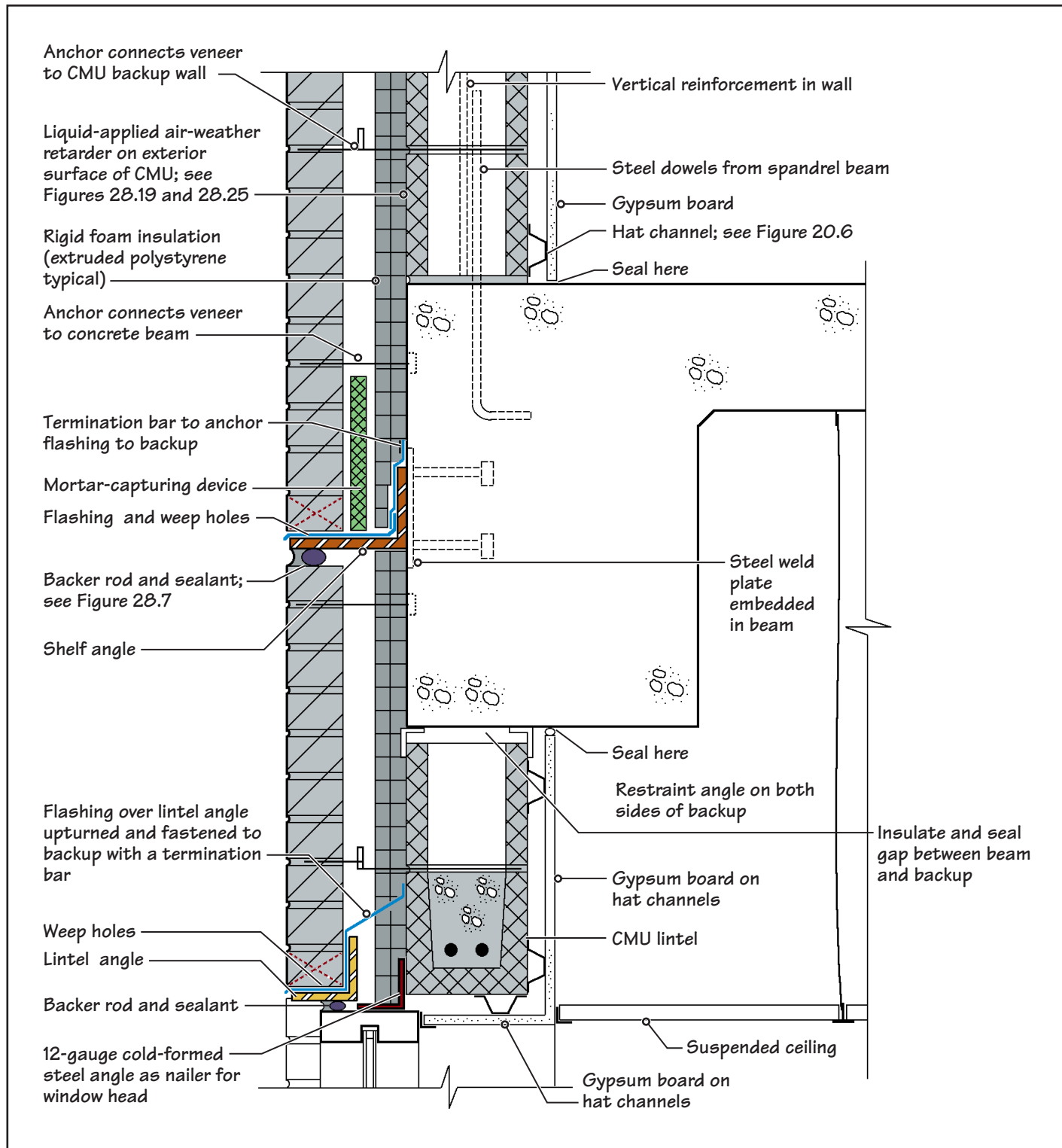

FIGURE 28.20 (b) This refers to Figure 28.20(a).

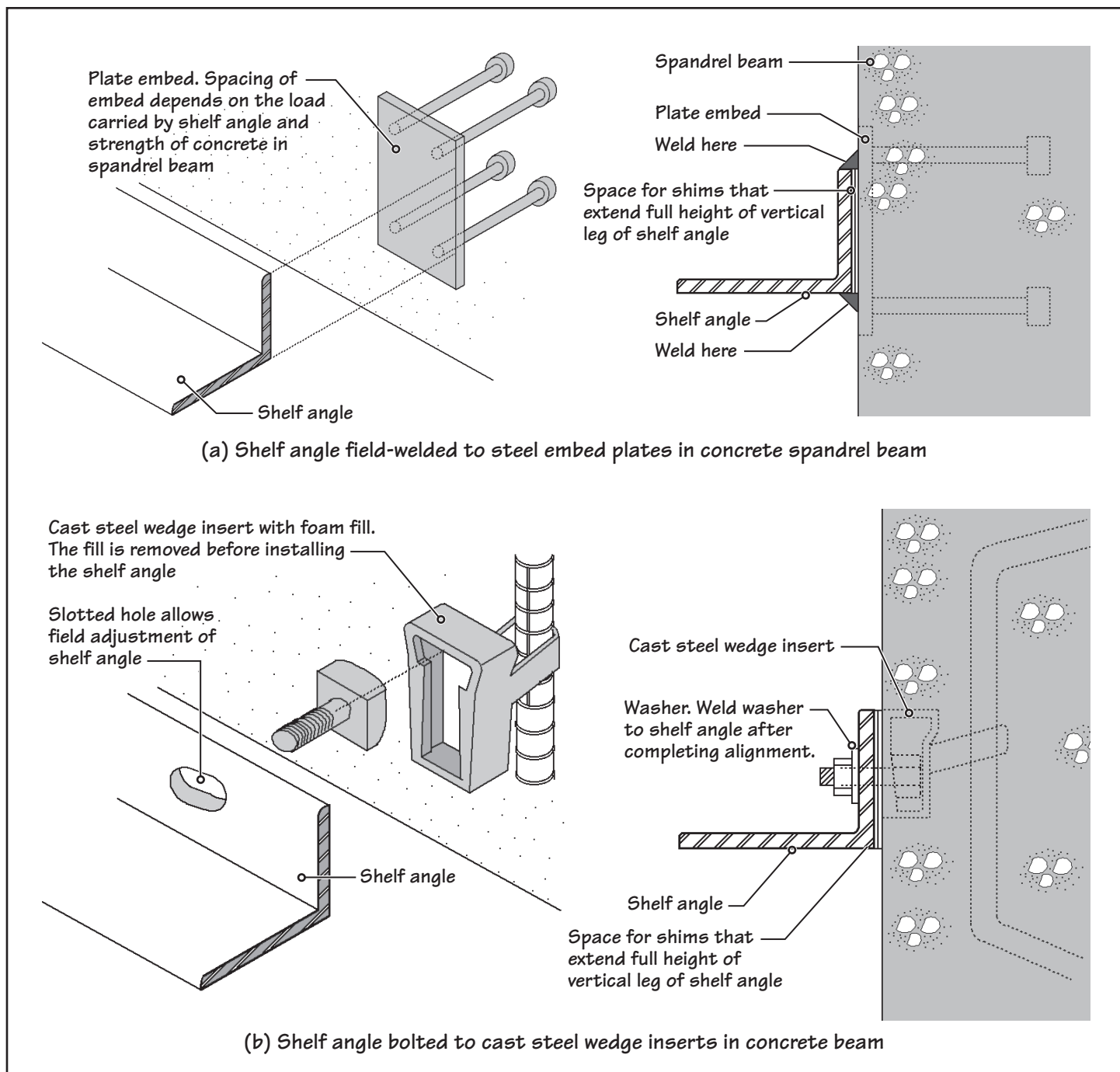

FIGURE 28.21 Two alternative methods of anchoring a shelf angle to a reinforced-concrete spandrel beam. Method (a) is more commonly used. In this method, the shelf angle for a given floor must be in place before the construction of the veneer below it begins. Method (b) allows the shelf angle to be installed after the veneer below the shelf angle has been constructed, and is needed where the veneer consists of large natural stone or cast-stone panels, requiring a mechanical lifting device to bring them into position from above.

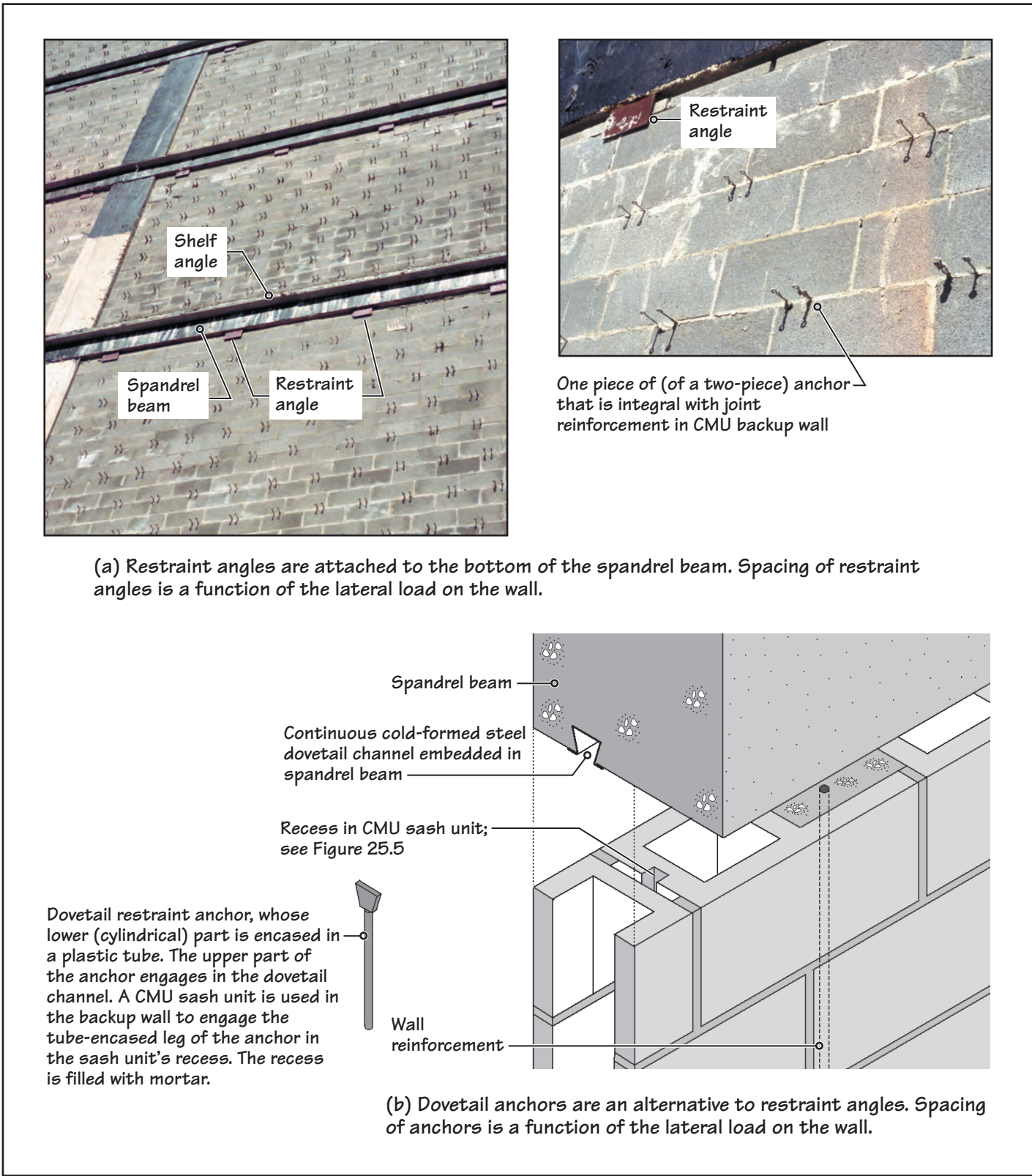

FIGURE 28.22 Two alternative methods of providing lateral load restraint at the top of a CMU backup wall.

The shelf angle and lintel angles can be combined into one by increasing the depth of the spandrel beam down to the level of the window head, Figure 28.23—a strategy that is commonly used with ribbon windows and continuous brick veneer spandrels, Figure 28.24.

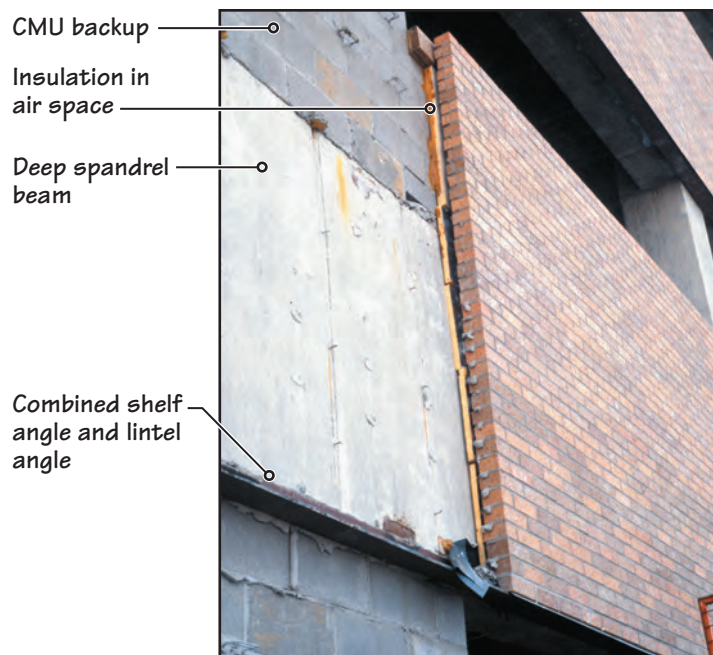

FIGURE 28.23 With a deep spandrel beam, which extends from the window head in the lower floor to the upper-floor level, the shelf angle and lintel angle are combined into one angle.



FIGURE 28.24 A building with brick veneer spandrels and ribbon windows.

AIR AND WATER RESISTANCE OF CMU BACKUP WALLS

It is important that the exterior face of CMU backup walls is suitably treated to resist the flow of air and water while allowing water vapor to pass through. Several proprietary liquid-applied air-weather barriers are available, which can be brushed on, sprayed on, or mop-applied, Figure 28.25.



FIGURE 28.25 The exterior surface of a CMU backup wall (and the underlying spandrel beam) has been treated with a liquid air-weather retarder (blue color) before the brick veneer is constructed.

28.3 BRICK VENEER WITH A STEEL STUD BACKUP WALL

The construction of brick veneer with a steel stud backup wall differs from that of a CMU-backed wall mainly in the anchors used for connecting the veneer to the backup. Various types of anchors are available to suit different conditions. The anchor shown in Figure 28.26 is used if the air space does not contain rigid foam insulation so that it is fastened to steel studs through exterior sheathing.

The anchor shown in Figure 28.27 is used if rigid foam insulation is present in the air space. The sharp ends of the prong-type anchor pierce the insulation (not the sheathing) and transfer lateral load to the studs without compressing the insulation.

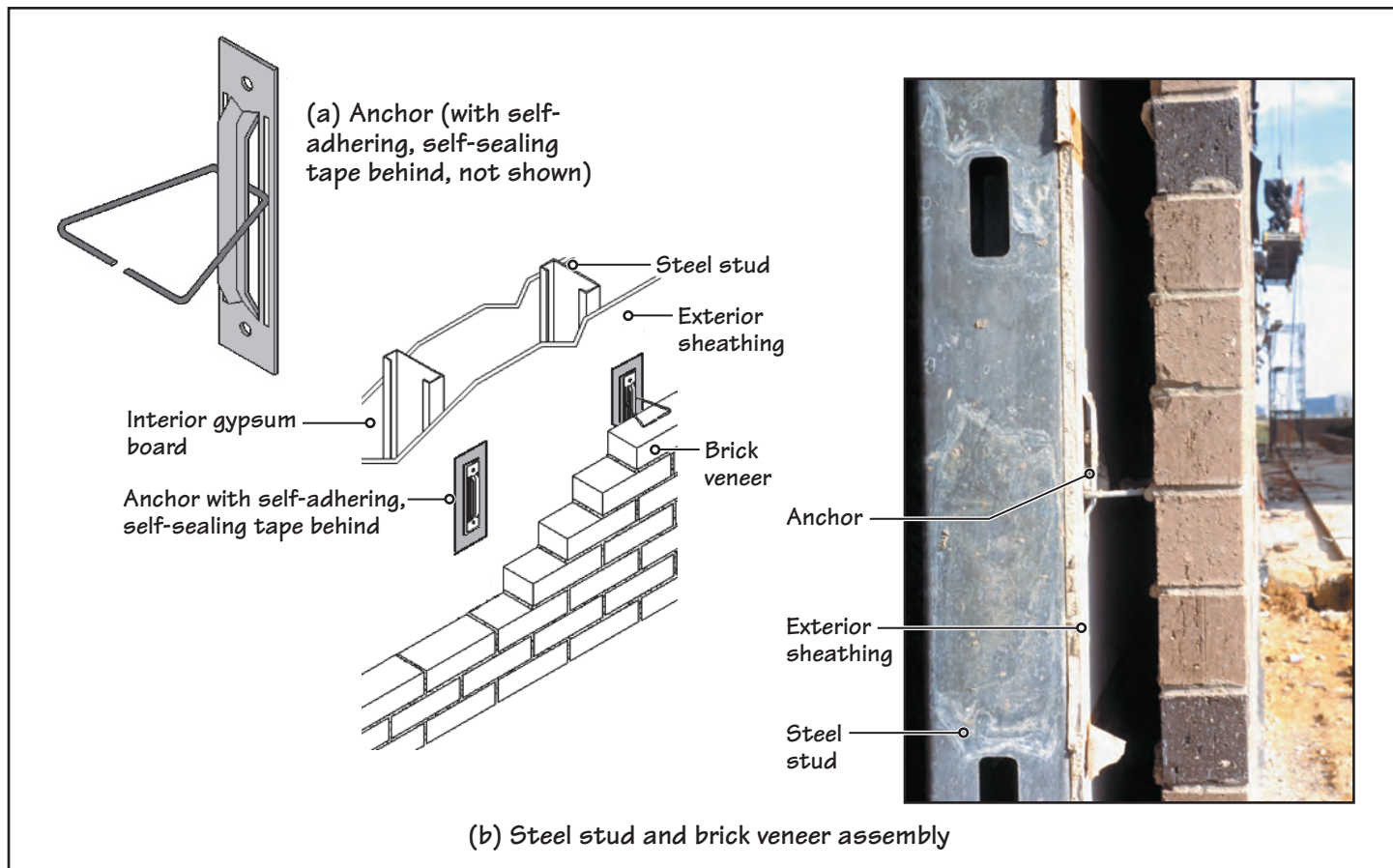

FIGURE 28.26 A typical anchor used in a steel stud and brick veneer assembly with insulation provided between studs; no insulation is provided outside of the exterior sheathing.

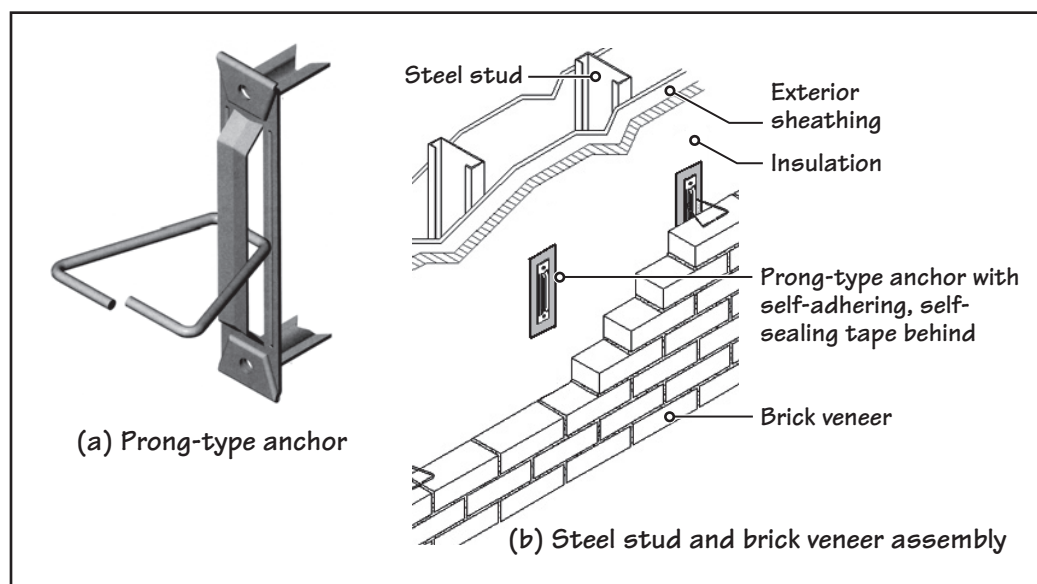

FIGURE 28.27 A typical steel stud and brick veneer assembly with insulation provided outside of the exterior sheathing (insulation may or may not be provided between studs); this requires a prong-type anchor. (Illustration courtesy of Hohmann and Barnard, Inc.)

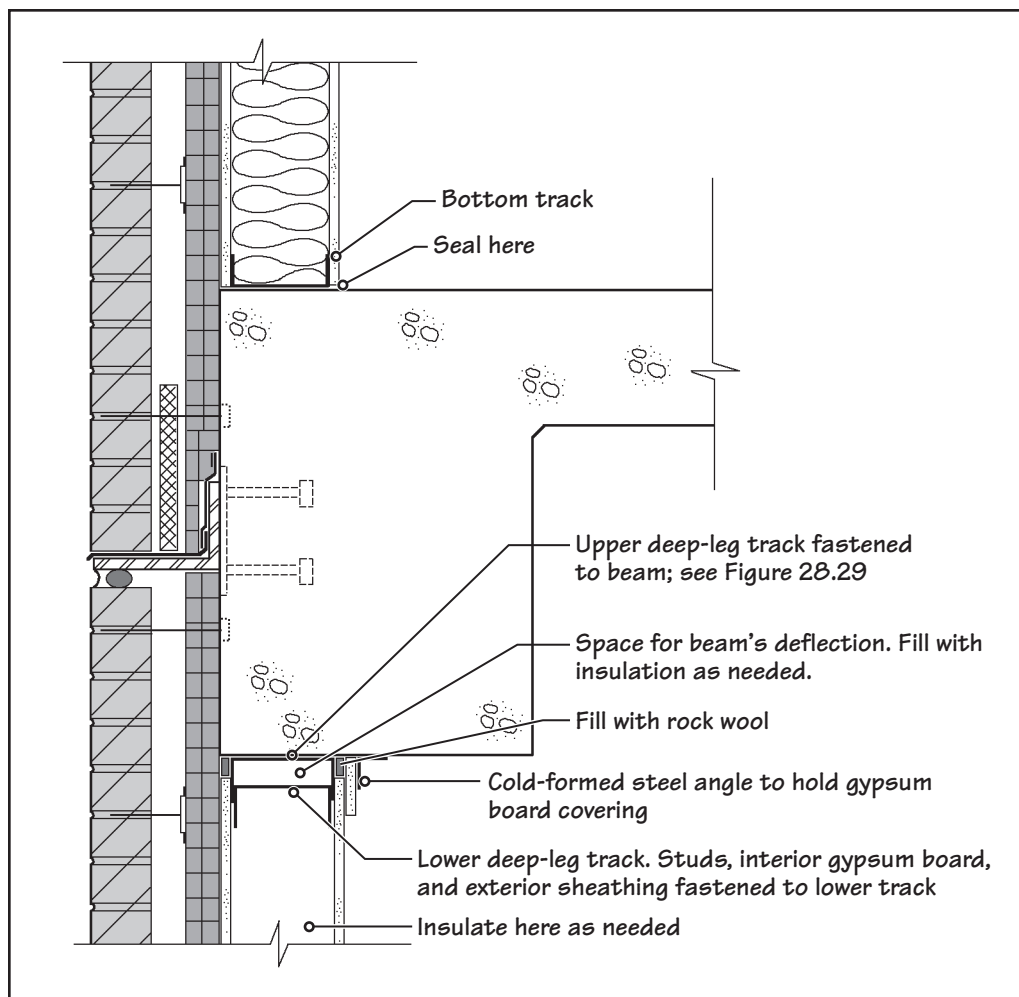

FIGURE 28.28 Detail of a typical steel stud and brick veneer assembly in a reinforced-concrete structure. The shelf angle, mortar-capturing device, flashing, and other details have not been labeled on the illustration for the sake of clarity. See also Figure 20.10.

STEEL STUD BACKUP WALL AS INFILL WITHIN THE STRUCTURAL FRAME

Figure 28.28 shows a detailed section of brick veneer applied to a steel stud backup wall with a reinforced-concrete structural frame. The (vertical) deflection of the spandrel beam is accommodated by providing a two-track assembly consisting of two nested deep-leg tracks, Figure 28.29(a). The upper track of this slip assembly is fastened to the beam. The

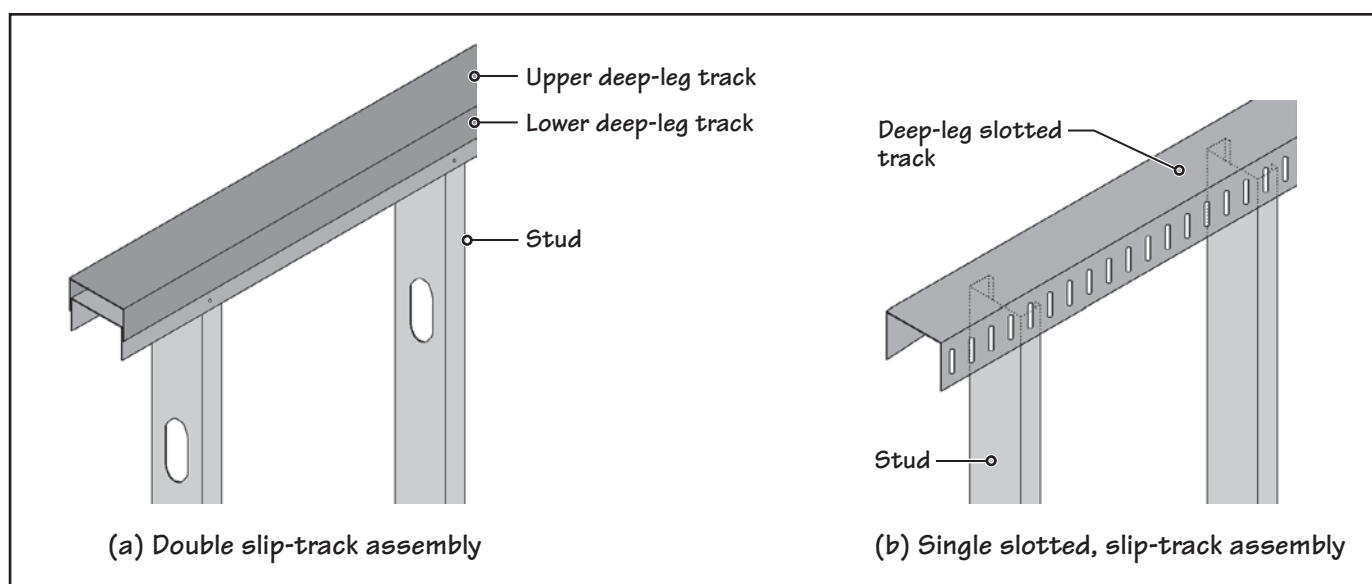

FIGURE 28.29 Two alternative methods of providing a slip-track assembly in a steel stud backup wall (refers to Figure 28.28).

studs and the interior drywall are fastened only to the lower track, which allows the upper track to slide over the lower track (see also Chapter 20, Section 20.5).

Alternatively, a single slotted, deep-leg slip-track assembly may be used. See Figure 28.29(b). The studs are loosely fastened to the top track through the slots. The drywall is not fastened to the slotted track. The slotted track assembly is more economical and also provides a positive connection between the track and the studs.

STEEL STUD BACKUP WALL FORWARD OF THE STRUCTURAL FRAME

In low-rise buildings (one or two stories), putting the steel stud backup wall on the outside of the structure allows it to cover the structural frame. Thus, the studs are continuous from the bottom to the top, requiring no shelf angles, Figures 28.30 and 28.31.

Slip connections must be used to connect the studs with the floor or roof so that the structural frame and the wall can move independently of each other. Two of the several alternative means of providing slip connections are shown in Figure 28.32.

A brick veneer attached to a steel stud backup wall forward of the structure can also be used in mid- and high-rise buildings. Two alternative details commonly used for buildings with ribbon windows and brick spandrels are shown in Figures 28.33 and 28.34.

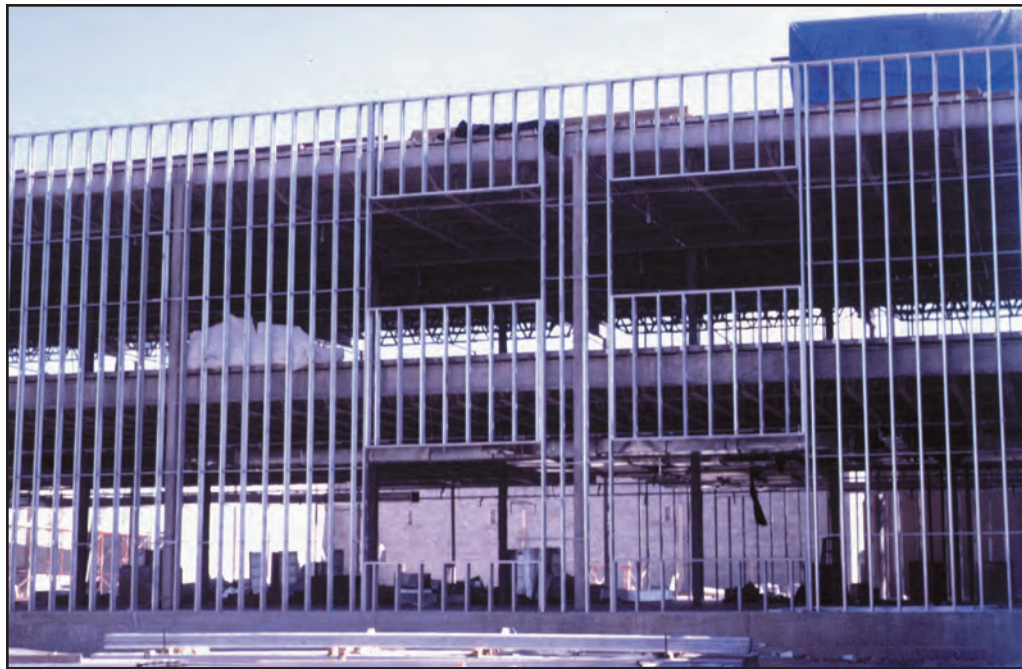

FIGURE 28.30 In a one- or two-story building with a steel stud backup wall and a steel-frame structure, the studs are generally continuous from the foundation to the roof. The vertical continuity of studs across a floor and (or) roof increases their lateral load resistance. Refer to Figures 28.31 and 28.32 for details.

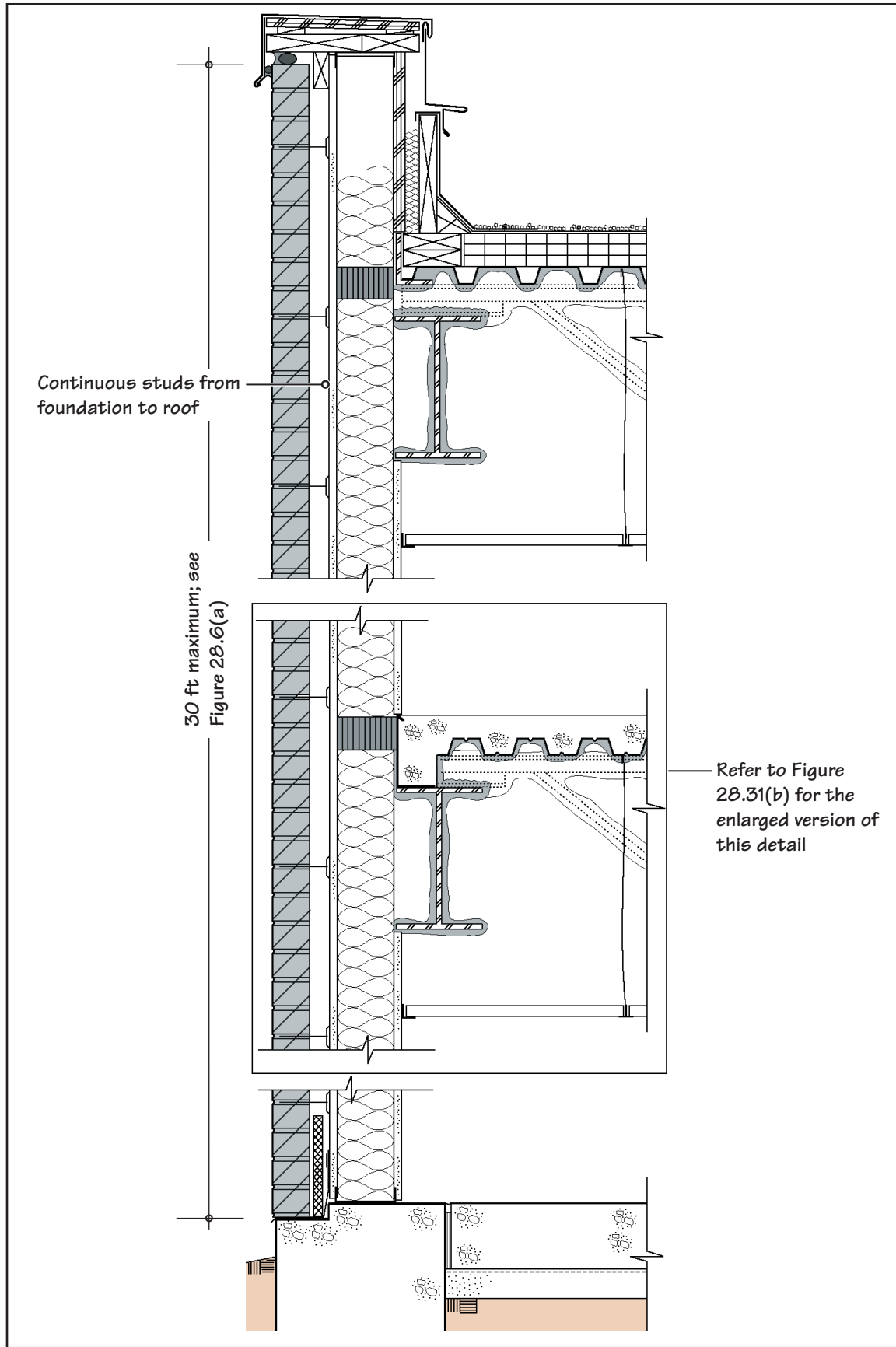

FIGURE 28.31 (a) A typical section through a low-rise (one- or two-story) steel-frame building with a brick veneer and steel stud backup wall assembly. Steel studs in the backup framing are continuous from the foundation to the roof (refer to the details in Figures 28.31(b) and 28.32).

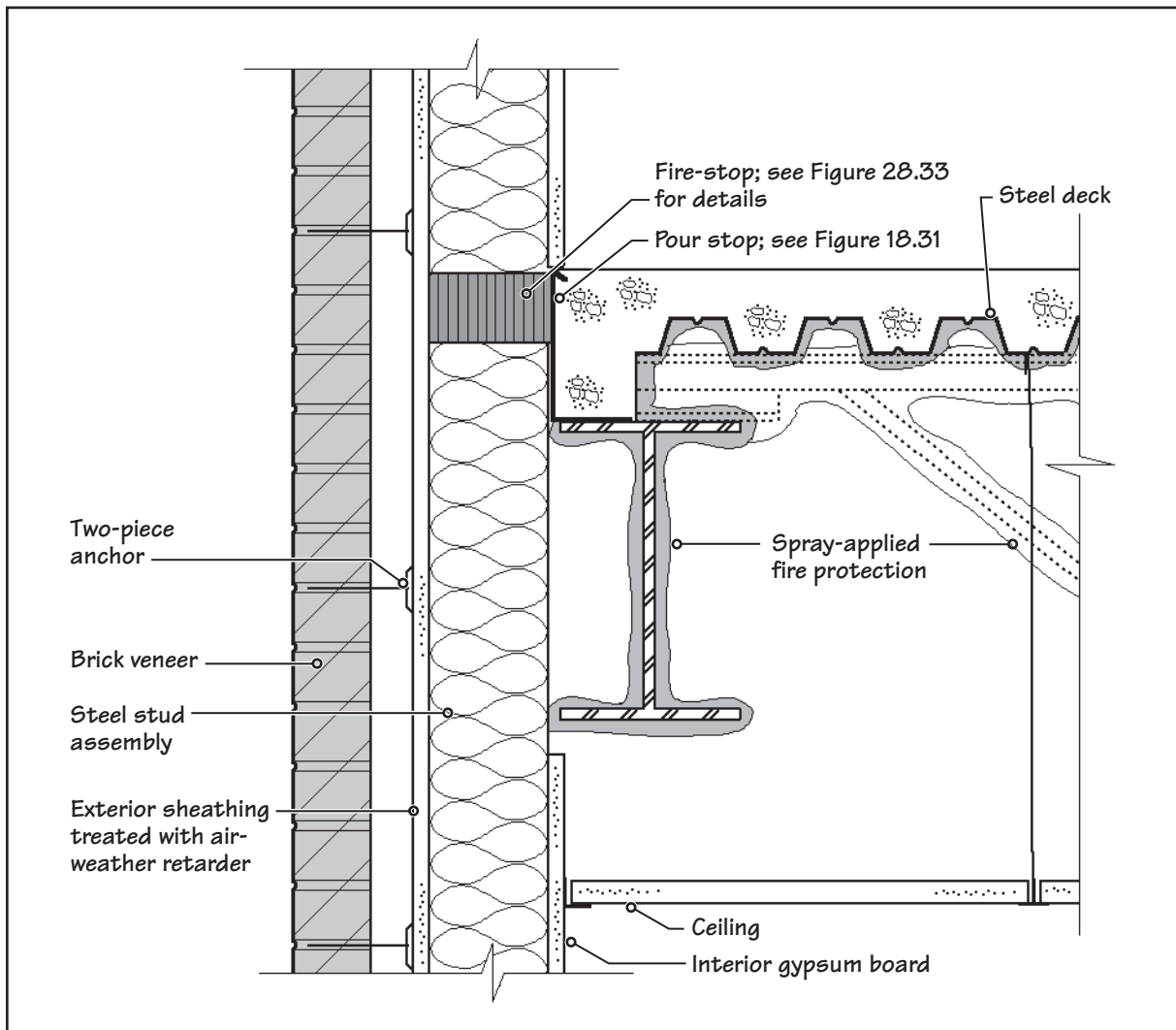

FIGURE 28.31 (b) Enlarged version of the detail at the floor level, which refers to Figure 28.31(a). Note that a slip connection between the steel studs and the floor (and roof) frame is required (see Figure 28.32).

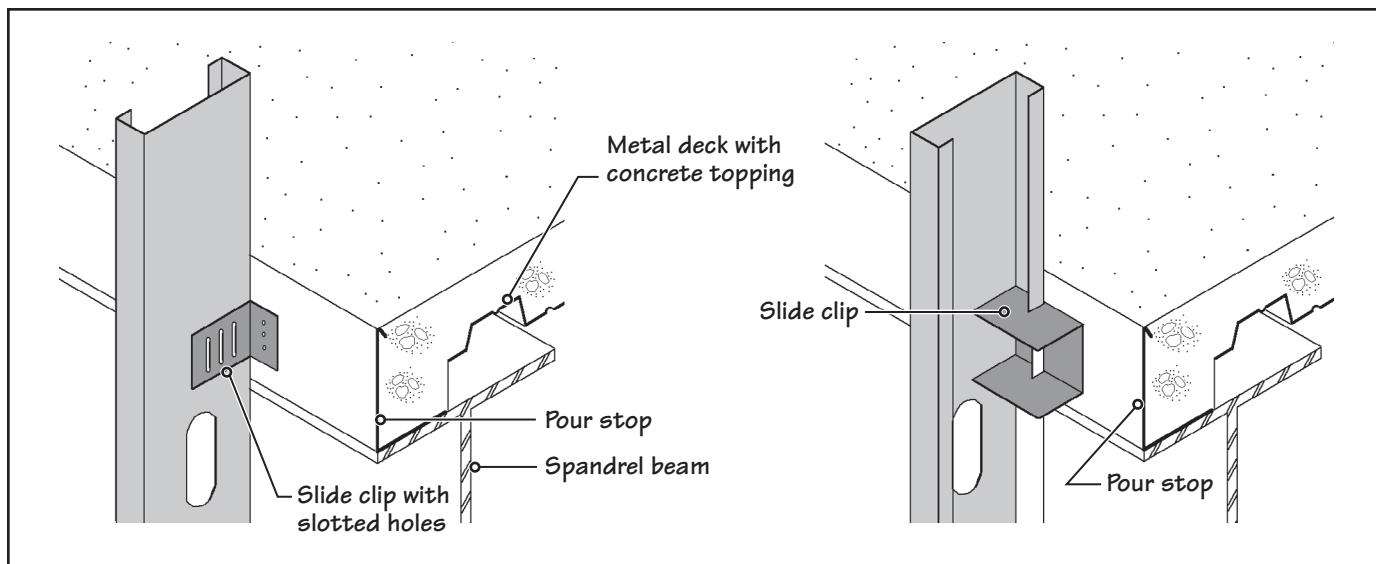

FIGURE 28.32 Two alternative methods of providing a slip connection between a steel stud backup wall and the floor/roof structure; this refers to Figure 28.31.

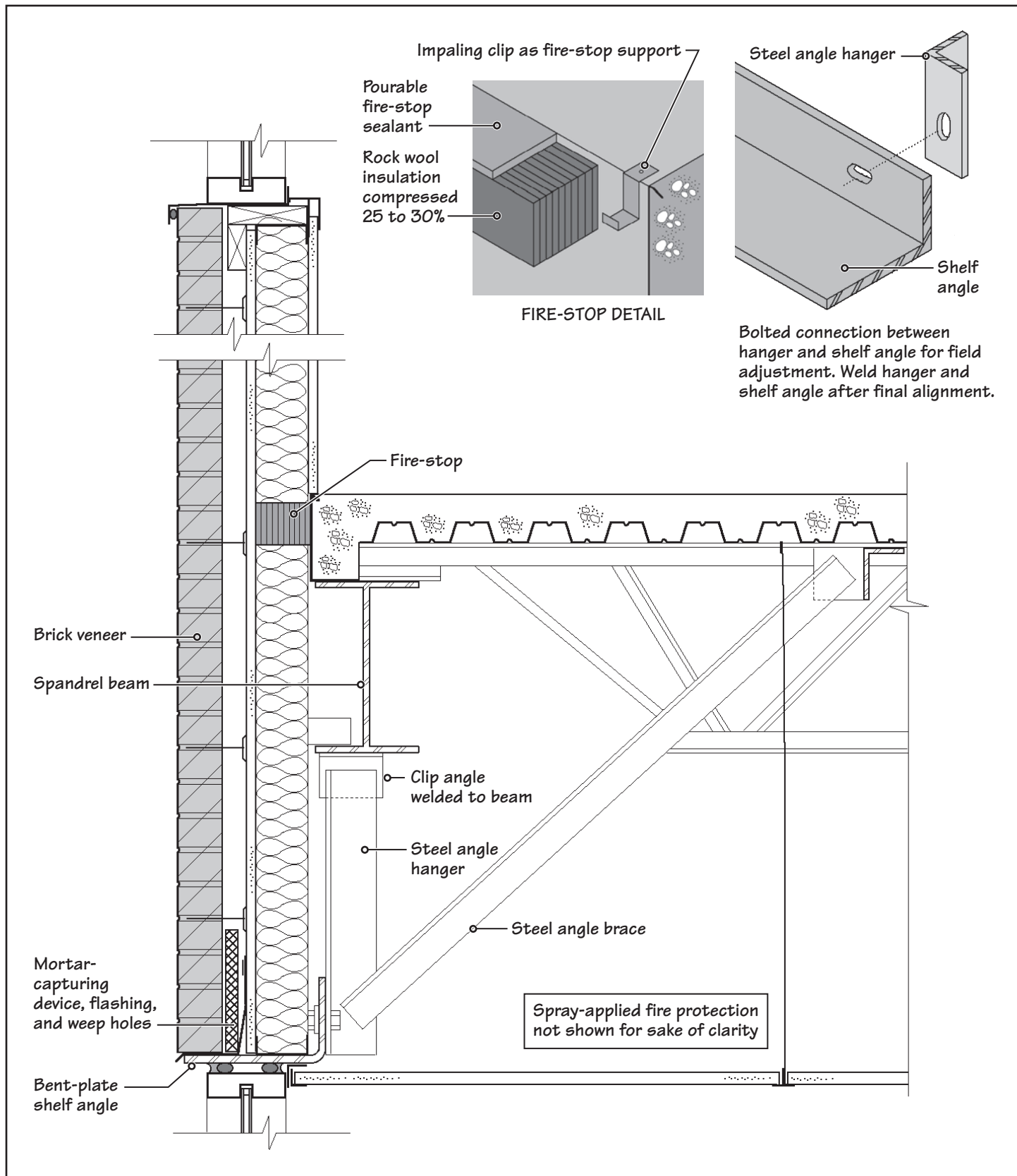

FIGURE 28.33 Brick spandrel with a steel stud backup wall. Steel studs and brick veneer bear on a bent-plate shelf angle. (For a discussion of bent-plate angles, see Chapter 18, Section 18.4.)

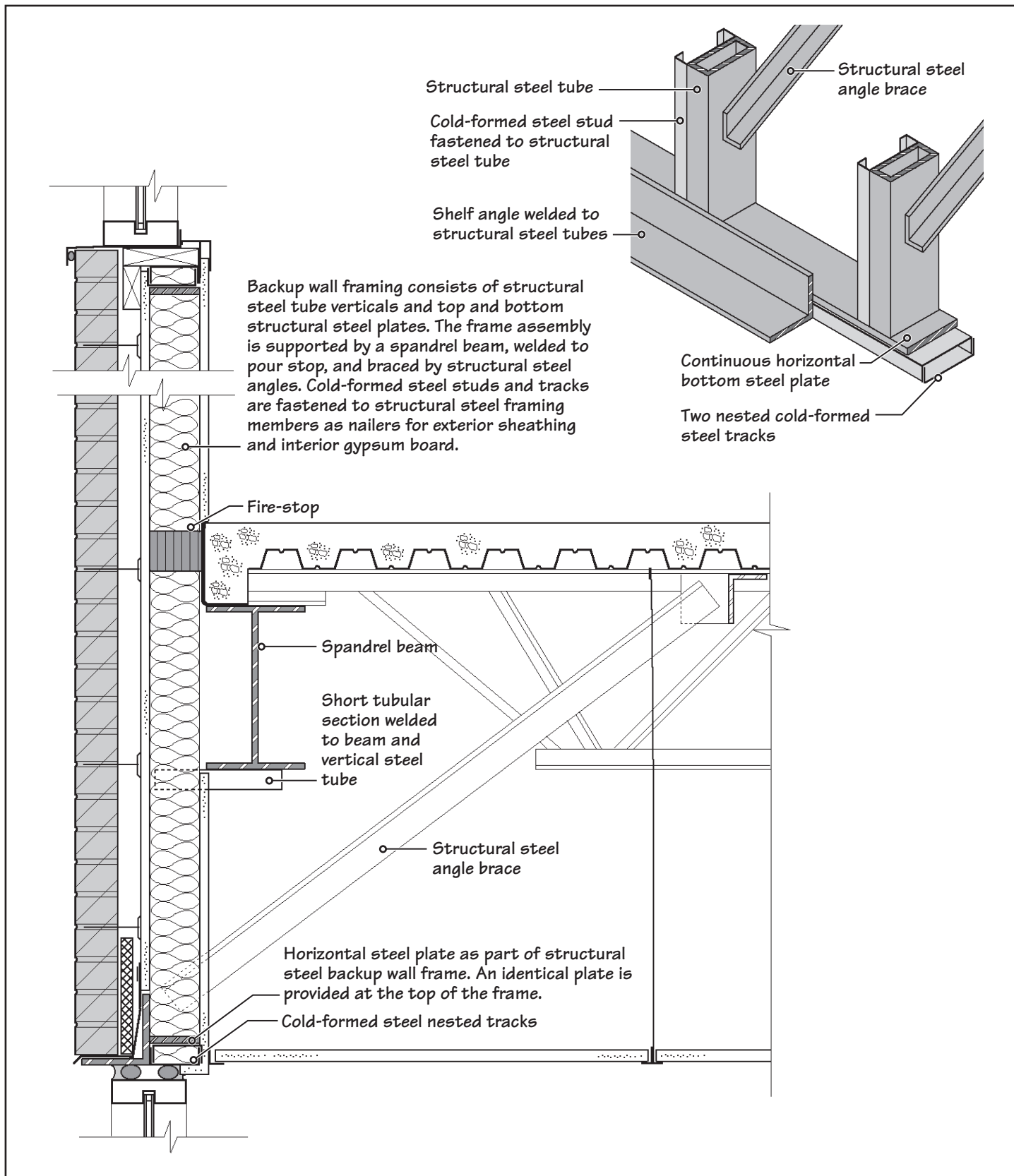

FIGURE 28.34 (a) Brick spandrel with structural steel backup wall framing. The shelf angle is hung from the structural steel frame and supports only the brick veneer (and insulation outside of the exterior sheathing, where provided); also see Figure 28.34(b).

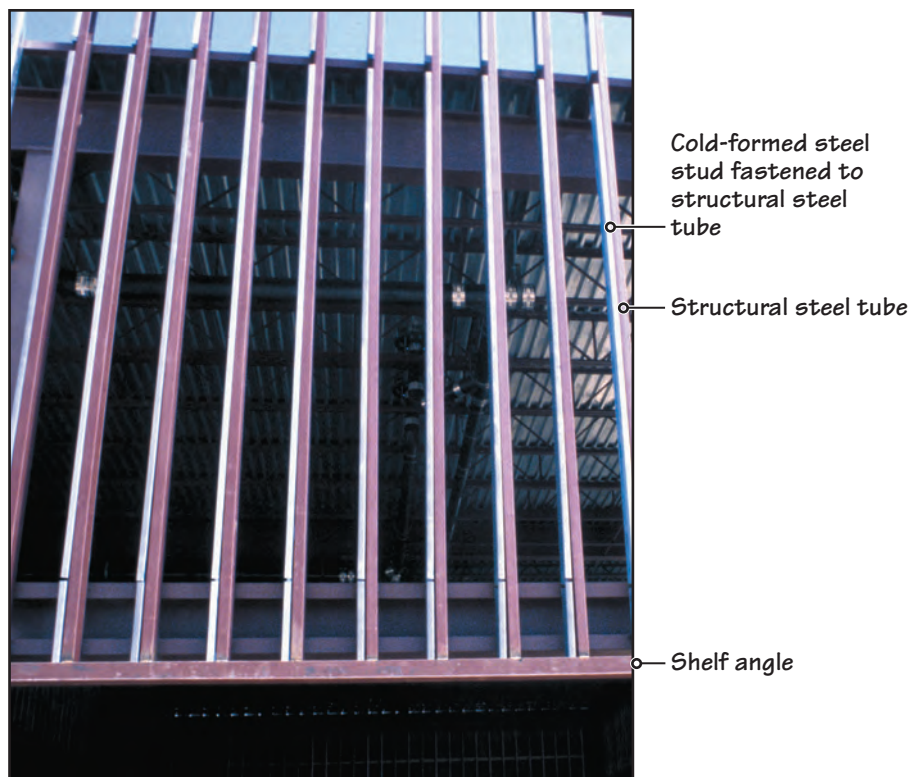

FIGURE 28.34 (b) Structural steel framing for a brick veneer panel. The framing is supported by the floor and roof beams. The shelf angle is hung from the vertical structural steel frame and supports only the brick veneer.

AIR AND WATER RESISTANCE OF A STEEL STUD BACKUP WALL

Weather resistance of exterior sheathing on steel studs is necessary, and may be accomplished by using either (a) a wrap-type air-weather retarder or (b) a liquid-applied air-weather retarder. The latter alternative is more commonly used for commercial buildings.

28.4 CMU BACKUP VERSUS STEEL STUD BACKUP

A major benefit of a steel stud backup wall in a brick veneer assembly (compared with a CMU backup wall) is its lighter weight. For a high-rise building, the lighter wall not only reduces the size of spandrel beams but also that of the columns and footings, yielding economy in the building's structure. However, this benefit is accompanied by several concerns.

Steel studs can deflect considerably before the bending stress in them exceeds their ultimate capacity. Brick veneer, on the other hand, deflects by a very small amount before the mortar joints open. Open mortar joints weaken the wall and increase the probability of leakage, corroding the anchors.

Thus, the steel stud backup and brick veneer assembly performs well only if the stud wall is sufficiently stiff. To obtain the necessary stiffness, the deflection of studs must be controlled to a fairly small value. In fact, the design of a steel stud backup wall to resist the lateral loads is governed not by the strength of studs but by their deflection.

The Brick Industry Association (BIA) recommends that the lateral load deflection of steel studs, when used as backup for brick veneer assembly, should not exceed

$$\frac{\text{stud span}}{600}$$

where the stud span is the unsupported height of studs. For example, if the height of studs (e.g., from the top of the floor to the bottom of the spandrel beam in Figure 28.7) is 10 ft, the deflection of studs under the lateral load must be less than

$$\frac{(10 \times 12)}{600} = 0.5 \text{ in.}$$

Increasing the stiffness of studs increases the cost of the assembly. Another concern with steel stud backup is that the veneer is anchored to the backup only through screws that engage the threads within a cold-formed stud sheet. Over a period of time, condensation

NOTE

Deflection of a Steel Stud Wall Assembly

The design criterion of deflection not exceeding span divided by 600, suggested by BIA, is the minimum requirement. For critical buildings, a more stringent deflection criterion, such as span divided by 720 or span divided by 900, is recommended by some experts.

Steel stud manufacturers generally provide tables for the selection of their studs to conform to the deflection criteria.



(a)



(b)

FIGURE 28.35 (a) Use of recessed or projected bricks with different hues. The projections must be small so that the core holes in bricks are not exposed. (b) Precast (white) concrete members (of the same thickness as bricks) used as bands in veneer.



FIGURE 28.36 Warped brick veneer used in Frank Gehry's Peter B. Lewis Building, Cleveland, Ohio. (Photo courtesy of Doug Guth)

can corrode the screws and the corresponding holes in studs, causing the screws to come loose. Condensation is, therefore, an important concern in a steel stud-backed veneer. A more serious concern is that the anchor installer will miss the studs.

By comparison with steel studs, anchoring of brick veneer to a CMU backup wall does not depend on screws; hence, it is more forgiving. Additionally, the anchors in a CMU backup wall are embedded in the mortar joints, and if they are made of stainless steel, their corrosion probability is extremely low.

Another advantage of a CMU backup wall is its inherent stiffness. Obtaining a steel stud backup wall of the same stiffness as a CMU backup wall substantially increases the cost of the stud backup.

28.5 AESTHETICS OF BRICK VENEER

It is neither possible nor within the scope of this text to illustrate the various techniques used to add visual interest to brick veneer facades. However, a few examples are provided:

- Using recessed or projected bricks in the wall, Figure 28.35(a).
- Using bricks of different colors or combining clay bricks with other masonry materials or cast concrete, Figure 28.35(b).
- Warping the wall, Figure 28.36.

PRACTICE QUIZ

Each question has only one correct answer. Select the choice that best answers the question.

18. A typical anchor used with a brick veneer and CMU backup wall assembly consists of a
- a. two-piece anchor, of which one is embedded in the CMU backup wall and the other is embedded in the veneer's mortar joint.
 - b. three-piece anchor, of which two are fastened to the CMU backup wall and the other is embedded in the veneer's mortar joint.
 - c. two-piece anchor, of which one is an integral part of the joint reinforcement in the CMU backup wall and the other is embedded in the veneer's mortar joint.
 - d. (a) and (b).
 - e. (a) and (c).
19. When lintel angles and shelf angles are combined in the same angle in a brick veneer-clad building, the angle should be treated as a
- a. lintel angle anchored to the structural frame of the building.
 - b. lintel angle loose-laid over underlying veneer.
 - c. shelf angle loose-laid over underlying veneer.
 - d. shelf angle anchored to the structural frame of the building.

PART 2

MATERIALS AND SYSTEMS
OF CONSTRUCTION

FIGURE 28.38 (a) A precast concrete panel being unloaded from the delivery truck for hoisting into position by a crane. (b) The same panel being hoisted into its final position.

In a PC curtain wall project, an important role for the architect is to work out the aesthetic expression of the panels (shapes, size, exterior finishes, etc.). This should be done in consultation with the precast plant. A great deal of coordination between the architect, engineer of record, general contractor, precast plant, and erection subcontractor is necessary for a successful PC curtain wall project.

Because of the sculptability of concrete and the assortment of possible finishes of the concrete surface (smooth, abrasive-blasted, acid-etched, etc.), PC curtain walls lend themselves to a variety of facade treatments. The use of reveals (aesthetic joints), moldings, and colored concrete further adds to the design variations, Figure 28.39.

PANEL SHAPES AND SIZES

Another key design decision is the size, shape, and function of each panel. These include window wall panels, spandrel panels, spandrel plus infill panels, and so on, Figure 28.40. The panels are generally one floor high, but those spanning two floors may be used.

PC wall panels are generally made as large as possible, limited only by the erection capacity of the crane, the transportation limitations, and the gravity load delivered by the panel to the structural frame. For structural reasons, the panels generally extend from column to column. Smaller panel sizes mean a larger number of panels, requiring a greater number of

CHAPTER 28

EXTERIOR WALL CLADDING—II
(MASONRY, PRECAST CONCRETE,
AND GFRG)

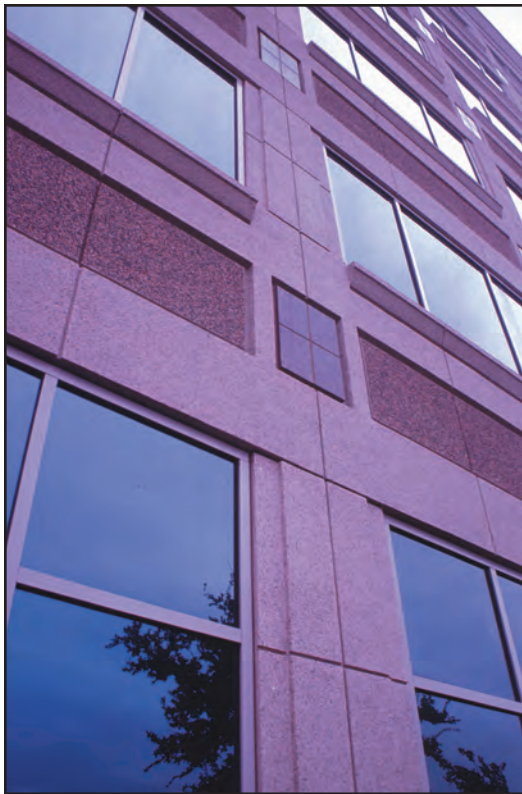

FIGURE 28.39 (a) Lightly abrasive-blasted panels with a great deal of surface detailing.



FIGURE 28.39 (b) The part of this panel on the left side of the reveal is lightly abrasive-blasted, and the right side part is medium abrasive-blasted.



FIGURE 28.39 (c) Panel with an exposed aggregate finish.

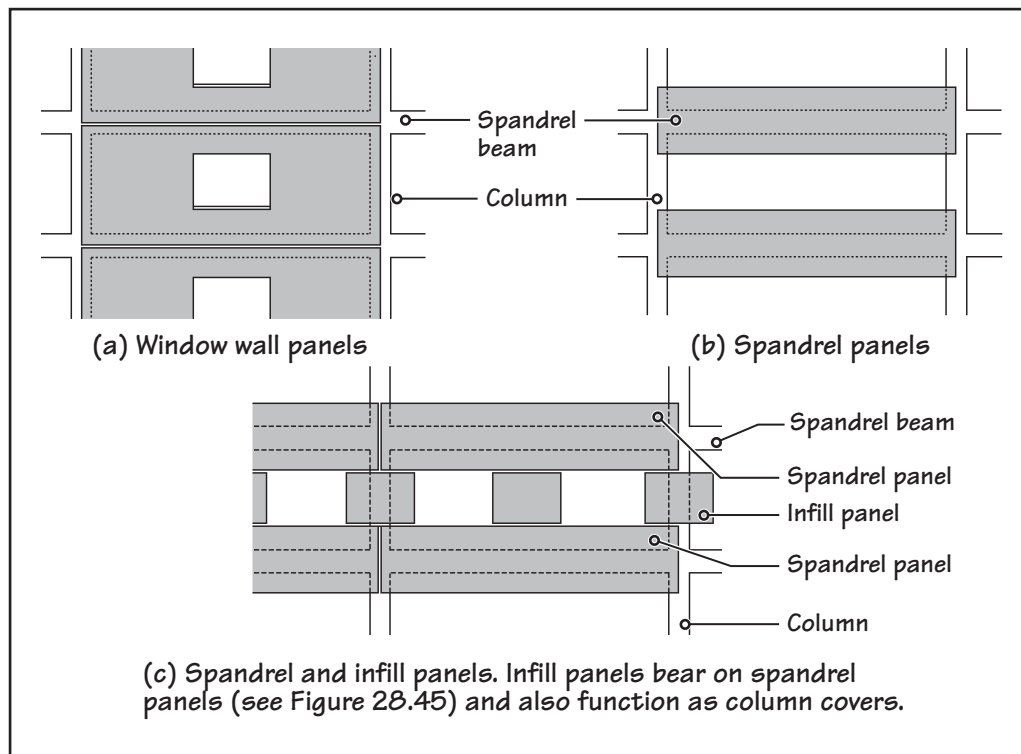

FIGURE 28.40 A few commonly used shapes of precast concrete wall panels. Panels should preferably extend from column to column so that their dead load (which is delivered through two supports only) is transferred to the beam as close to the columns as possible (see Section 28.7).

support connections, longer erection time, and, hence, a higher cost. If the scale of large panels is visually unacceptable, false joints can be incorporated in the panels, as shown in preceding images.

CONCRETE STRENGTH

PC curtain wall panels are removed from the form as soon as possible to allow rapid turnover and reuse of the formwork. This implies that the 28-day concrete strength should be reasonably high so that when the panel is removed from the form, it can resist the stresses to which it may be subjected during the removal and handling processes.

The required concrete strength is also a function of the curtain wall's exposure, durability requirements, shape, and size of the panels. Flat panels may require higher strength (or greater thickness) compared to ribbed or profiled panels. Therefore, the strength of concrete must be established in consultation with the precast plant supplying the panels.

The most commonly used 28-day strength of concrete for PC curtain wall panels is 5,000 psi. This relatively high strength gives greater durability, greater resistance to rainwater penetration, and improved in-service performance. In other words, the panels are better able to resist stresses caused by the loads, building movement, and volume changes induced by thermal, creep, and shrinkage effects.

For aesthetic and economic reasons, a panel may use two mixes—a face (architectural) mix and a backup (structural) mix. In this case, the two mixes should have nearly equal expansion and contraction coefficients to prevent undue bowing and warping of the panel. In other words, the strength, slump, and water-cement ratios of the two mixes should be nearly the same.

Because panels are generally fabricated face down on flat formwork, the face mix is placed first, followed by the backup mix. The thickness of the face mix is a function of the aggregate size but should not be less than 1 in. The precaster's experience should be relied upon in determining the thicknesses and properties of the two mixes.

PANEL THICKNESS

The thickness of panels is generally governed by the handling (erection) stresses rather than the stresses caused by in-service loads. A concrete cover on both sides and the two-way reinforcement in a panel generally give a total of about 4 in. of thickness. Add to this the thickness that will be lost due to surface treatment, such as abrasive blasting and acid etching, and the total thickness of a PC wall panel cannot be less than 5 in.

However, because panel size is generally maximized, a panel thickness of less than 6 in. is rare. A thicker panel is not only stronger but is also more durable, is more resistant to water leakage, and has higher fire resistance. Greater thickness also provides greater heat-storage capacity (Chapter 5), making the panel less susceptible to heat-induced stresses.

MOCK-UP SAMPLE(S)

For PC curtain wall projects, the architect requires the precast plant to prepare and submit for approval a sample or samples of color, texture, and finish. The *mock-up* panels, when approved, are generally kept at the construction site and become the basis for judgment of all panels produced by the precast plant.

28.7 CONNECTING THE PC CURTAIN WALL TO A STRUCTURE

The connections of PC curtain wall panels to the building's structure are among the most critical items in a PC curtain wall project and are typically designed by the panel fabricator. Two types of connections are required in each panel:

- Gravity load connections
- Lateral load connection

There should be only two gravity load connections, also referred to as *bearing supports*, per panel located as close to the columns as possible. The lateral load connections, also referred to as *tiebacks*, may be as many as needed by structural considerations, generally two or more per panel, Figure 28.41.

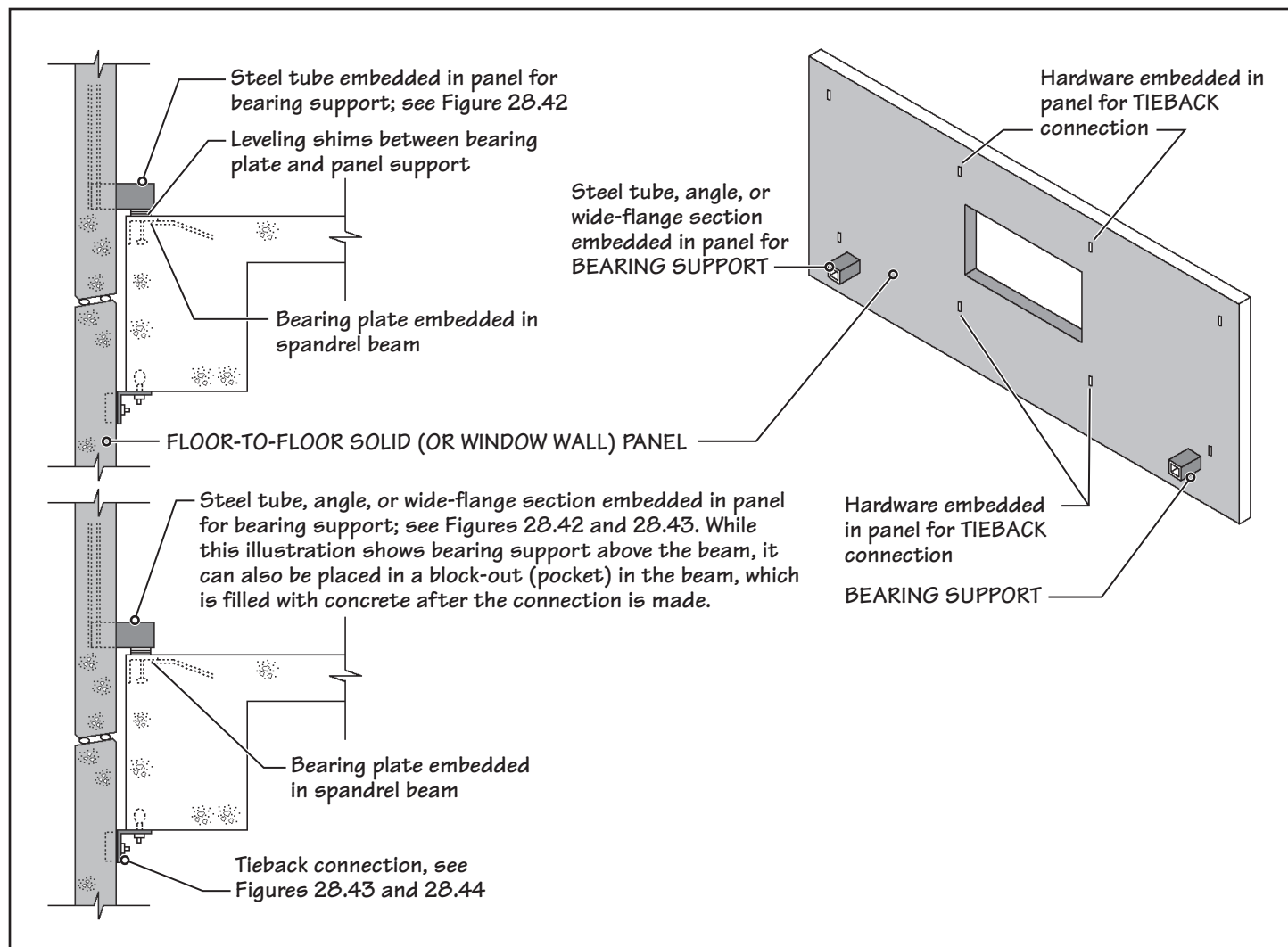

FIGURE 28.41 Support connections for a typical floor-to-floor curtain wall panel.

BEARING SUPPORTS

A commonly used bearing support for floor-to-floor panels is provided by a section of steel tube, part of which is embedded in the panel and part of which projects out of the panel. The projecting part rests on the (steel angle) bearing plate embedded at the edge of the spandrel beam. Dimensional irregularities, both in the panel and in the structure, require the use of leveling shims (or bolts) under bearing supports during erection.

After the panels have been leveled, the bearing supports are welded to the bearing plate. The bearing support system is designed to allow the panel to move within its own plane so that the panel is not subjected to stresses induced by temperature, shrinkage, and creep effects.

In place of leveling shims in a bearing support, a leveling bolt is often used, Figure 28.42. The choice between the shims and the bolt is generally left to the preference of the precast manufacturer and the erector. Alternatives to the use of steel tube for bearing supports are steel angles or a wide-flange (I-) section, Figure 28.43.

TIEBACKS

A lateral load connection (tieback) is designed to resist horizontal forces on the panel from wind and/or earthquake and due to the eccentricity of panel bearing. Therefore, it must be able to resist tension and compression perpendicular to the plane of the panel.

A tieback is designed to allow movement within the plane of the panel. The connection must, however, permit adjustment in all three principal directions during erection. A typical tieback is shown in Figure 28.44; see also Figure 28.43.

NOTE

The connection system of a PC curtain wall resembles that of a brick veneer connection system and is common to all types of curtain walls. The shelf angles in brick veneer provide the gravity load connection, and the anchors between the veneer and the backup wall provide the lateral load connection.

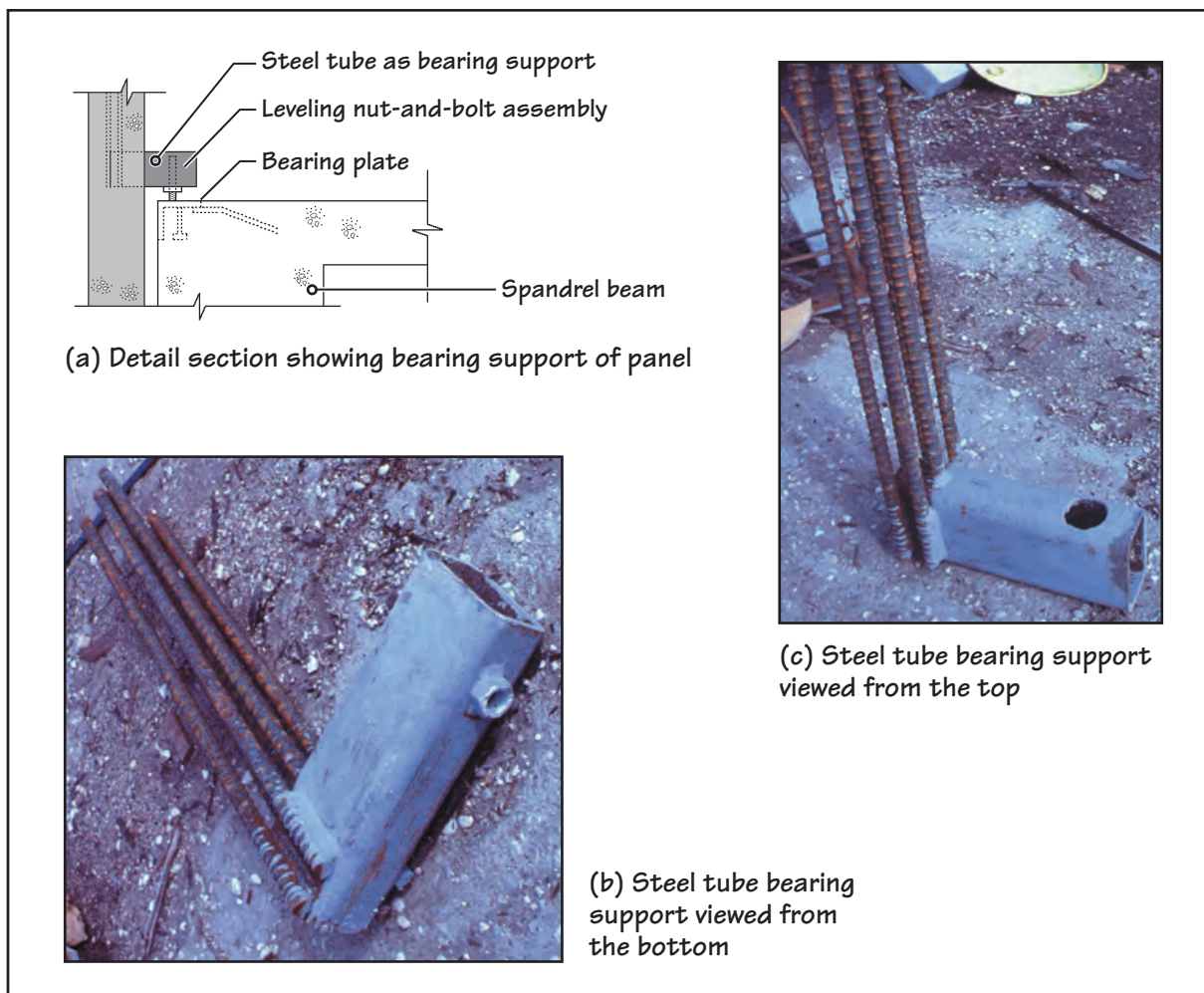

FIGURE 28.42 Steel tube as bearing support, and leveling nut and bolt.

SUPPORT SYSTEMS FOR SPANDREL PANELS AND INFILL PANELS

Support systems for a curtain wall consisting of spandrel and infill panels are shown in Figure 28.45; see also Figure 28.40(c).

PANELS AND STEEL FRAME STRUCTURE

PC wall panels, which create eccentric loading on the spandrel beams, create torsion in the beams. Due to the lower torsional resistance of wide-flange steel beams, PC panels used with a steel-frame structure are generally designed to span from column to column and made to bear directly on them. Tiebacks, however, are connected to the spandrel beams.

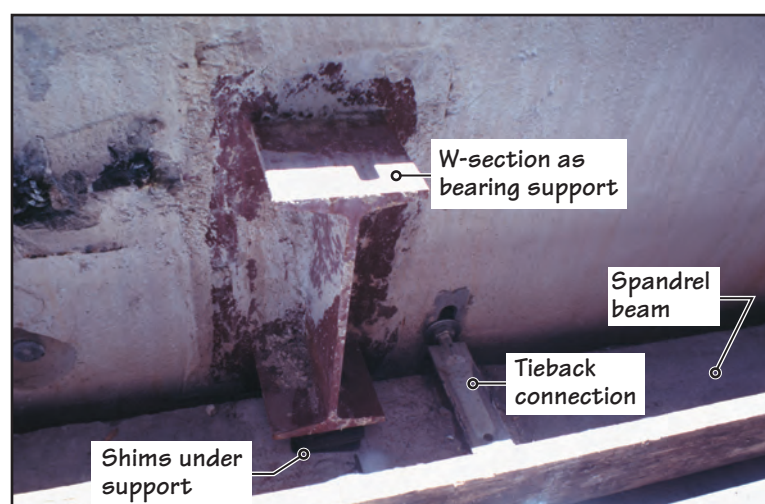

FIGURE 28.43 Wide-flange section used as bearing support in a PC panel.

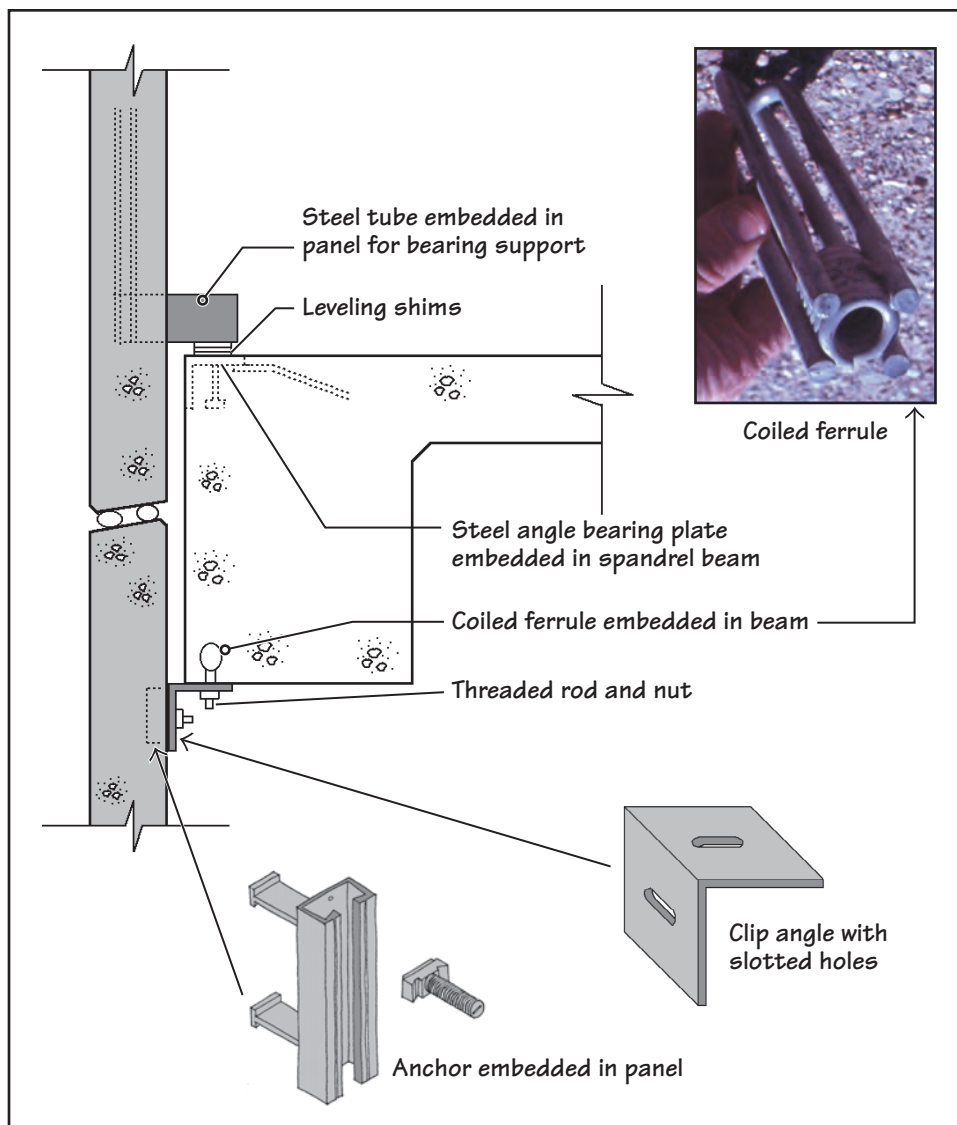

FIGURE 28.44 A typical tieback connection that allows three-way field adjustment during panel erection in addition to allowing in-service vertical deflection of the spandrel beam and thermal expansion/contraction of the panel.

CLEARANCE OF PANELS FROM THE STRUCTURAL FRAME

The Precast/Prestressed Concrete Institute (PCI) recommends a minimum horizontal clearance of 2 in. of precast panels from the building's structural frame.

28.8 BRICK AND STONE-FACED PC CURTAIN WALL

PC curtain wall panels may be faced with thin (clay) bricks at the time of casting the panels. Generally, $\frac{3}{4}$ - to 1-in.-thick bricks are used. They are available in various shapes, Figure 28.46. The bricks are placed in the desired pattern in the form, and the concrete is placed over them. To prevent the bricks from shifting during the placing operation, a rubber template is used, within which the bricks are placed, Figure 28.47. The template aligns the bricks and allows the concrete to simulate the mortar joints.

In well-designed and well-fabricated panels, it is generally difficult to distinguish between a site-constructed brick veneer wall and a brick-faced PC curtain wall. Brick-faced panels have the same advantages as other PC curtain wall panels—that is, no on-site construction and no scaffolding.

Thin bricks need to be far more dimensionally uniform than full-size bricks. With full-size bricks, dimensional nonuniformity is compensated for by varying the mortar thickness.

Because clay bricks expand by absorbing moisture from the atmosphere (moisture expansion), thin bricks should be allowed to season for a few weeks at the precaster's plant before

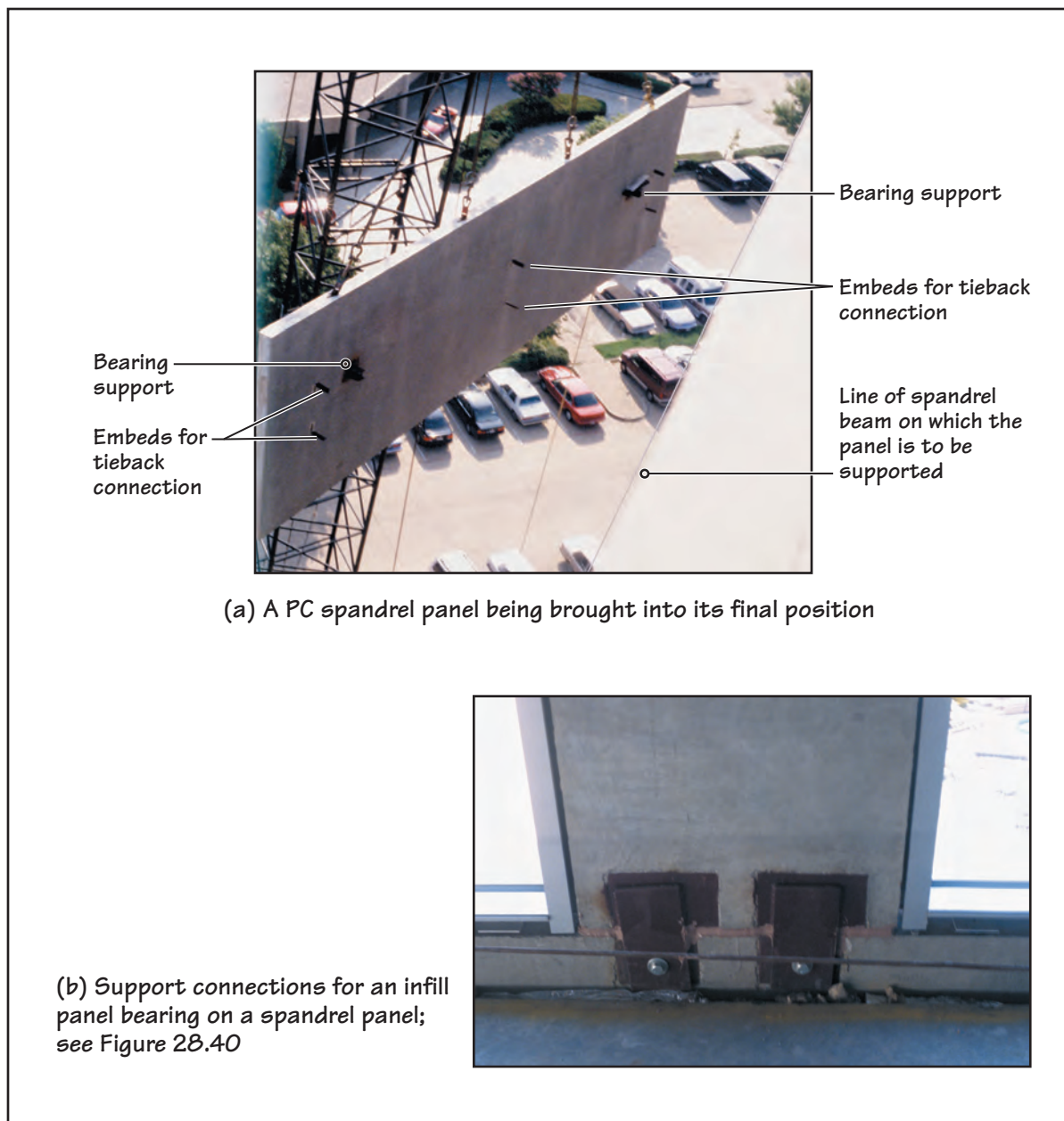

FIGURE 28.45 Support connections for (a) a spandrel panel and (b) an infill panel bearing on a spandrel panel.

being used. This reduces their inherent incompatibility with concrete, which shrinks on drying.

Although moisture expansion and drying shrinkage are the major causes of incompatibility between bricks and concrete, other differences between the two materials, such as the coefficient of thermal expansion and the modulus of elasticity, must also be considered. Because of these differences, a brick-faced concrete panel is subject to bowing due to differential expansion and contraction of the face and the backup.

Bowing can be reduced by increasing the stiffness of the panel. Using two layers of reinforcement is encouraged when the thickness of the panel permits. Additionally, some precasters use reverse curvature in the panels.

The bond between concrete and bricks is obviously very important for a brick-faced concrete wall panel. The back surface of bricks used in brick-faced panels should contain grooves, ribs, or dovetail slots to develop an adequate bond. The bond between concrete and brick is measured by a shear strength test. The architect should obtain the test results from the brick manufacturer before specifying the bricks for use.

The bond between concrete and bricks is also a function of how absorptive the bricks are. Bricks with excessively high or excessively low water absorption give a poor bond. Bricks with high water absorption are subjected to freeze-thaw damage.

STONE VENEER-FACED PC PANELS

PC curtain wall panels can also be faced with (natural) stone veneer. The thickness of the veneer varies with the type of stone and the face dimensions of the veneer units. Granite

and marble veneers are recommended to be at least $1\frac{1}{4}$ in. (3 cm) thick. Limestone veneer should be at least 2 in. (5 cm) thick.

The face dimensions of individual veneer units are generally limited to 25 ft² for granite and 15 ft² for marble or limestone. Thus, a typical PC curtain wall panel has several veneer units anchored to it.

The veneer is anchored to the concrete panel using stainless steel flexible dowels, whose diameter varies from $\frac{3}{16}$ to $\frac{5}{8}$ in. Two dowel shapes are commonly used—a U-shaped (hair-pin) dowel and a pair of cross-stitch dowels, Figure 28.48. The dowels are inserted in holes drilled in the veneer. The dowel holes, which are $\frac{1}{16}$ to $\frac{1}{8}$ in. larger in diameter than the diameter of the dowels, are filled with epoxy or an elastic, fast-curing silicone sealant. Unfilled holes allow water to seep in, leading to staining of the veneer and freeze-thaw damage.

Because the dowels are thin and flexible, they allow relative movement between the veneer and the backup. To further improve their flexibility, rubber washers are used with the dowels at the interface of the veneer and the backup.

The depth of anchor in the veneer is nearly half the veneer thickness. The anchorage into concrete varies, depending on the type of stone and the loads imposed on the panel.

There should be no bond between stone veneer and the backup concrete to prevent bowing of the panel and cracking and staining of the veneer. To prevent the bond, a bond breaker is used between the veneer and the backup. The bond breaker is either a 6- to 10-mil-thick polyethylene sheet or a $\frac{1}{8}$ - to $\frac{1}{4}$ -in.-thick compressible, closed-cell polyethylene foam board. Foam board is preferred because it gives better movement capability with an uneven stone surface.

A PC curtain wall panel may be fully veneered with stone or the veneer may be used only as an accent or feature strip on part of the panel.

OTHER FORM LINERS

Because concrete is a moldable material, several geometric and textured patterns can be embossed on panel surface using form liners. An architect can select from a variety of standard form liners or have them specially manufactured for a large project (see Section 22.4).

28.9 DETAILING A PC CURTAIN WALL

A typical PC curtain wall is backed by an infill steel stud wall. The stud wall provides the interior finish and includes the insulation, as well as electrical and other utility lines. Because the backup wall is not subjected to wind loads, it needs to be designed only for incidental lateral loads from the building's interior (minimum 5 psf). Therefore, a fairly lightweight backup wall is adequate. This contrasts with a backup stud wall in a brick veneer wall, which must be designed to resist wind loads and be sufficiently stiff to have a relatively small deflection.

Figure 28.49 shows a representative detail of a PC curtain wall with a steel stud backup wall. The space between the panels and the backup wall may be filled with rigid insulation, if needed.

WATER INTRUSION CONTROL AND JOINTS BETWEEN PANELS

Concrete walls are sufficiently water resistant. Therefore, PC curtain walls do not require the same level of water intrusion control as brick veneer walls. However, the joints between panels must be treated with a backer rod and sealant.

A minimum joint width of 1 in. between panels is generally recommended. Although a single-stage joint is commonly used, the preferred method is to use a two-stage joint system, consisting of a pair of backer rod and sealant bead combinations. One backer rod and sealant bead combination is placed toward the outer surface of the joint and the other is placed toward the inner surface, Figure 28.50.

The outer seal provides a weather barrier and contains weep holes. The inner seal is continuous, without any openings, and is meant to provide an air barrier. The air barrier must extend continuously over a panel and across the joint between panels. The provision of the air barrier and the openings in the exterior seal make the two-stage joint system function as a rain screen (see Chapter 27).

CHAPTER 28

EXTERIOR WALL CLADDING—II
(MASONRY, PRECAST CONCRETE,
AND GFRG)

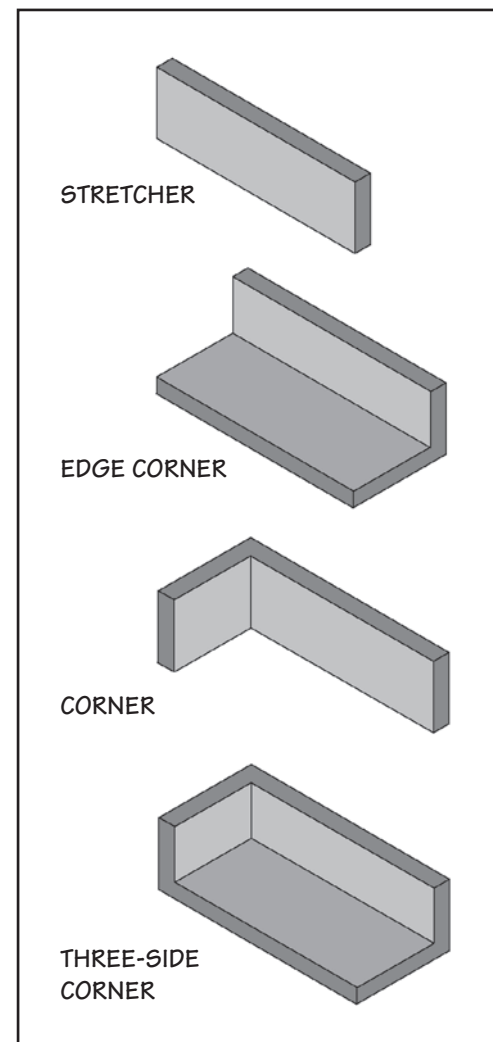

FIGURE 28.46 A few thin clay brick shapes.



FIGURE 28.47 A rubber template form liner used with thin brick-faced panels.

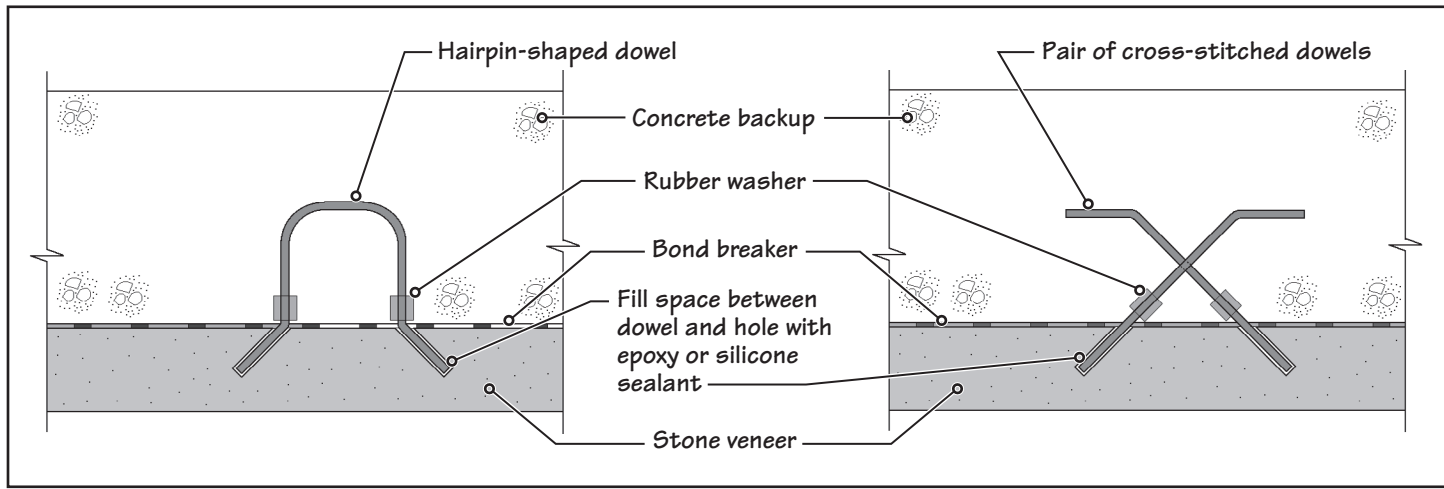

FIGURE 28.48 Two commonly used dowel anchors.

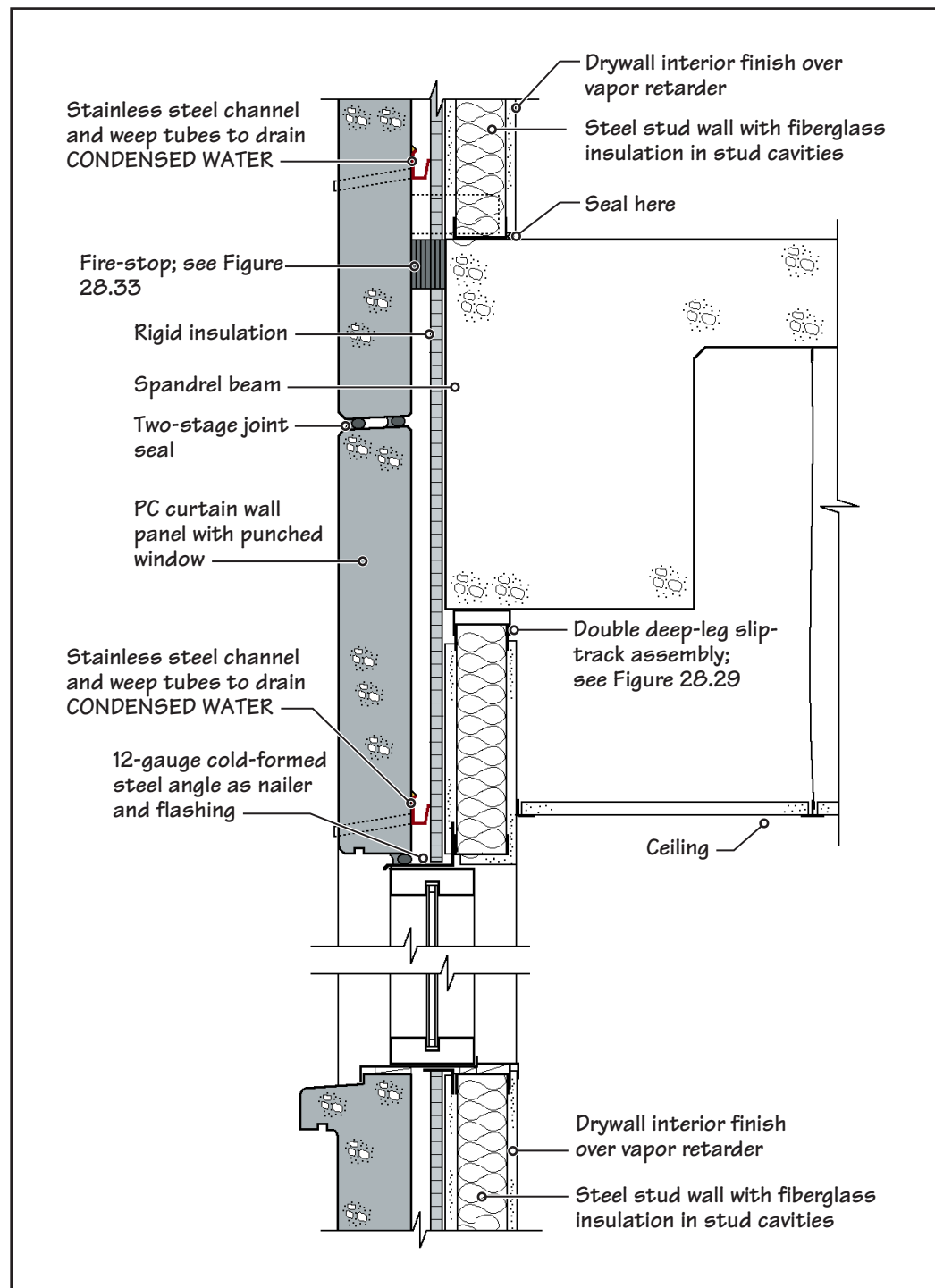

FIGURE 28.49 A typical PC curtain wall (schematic) detail.

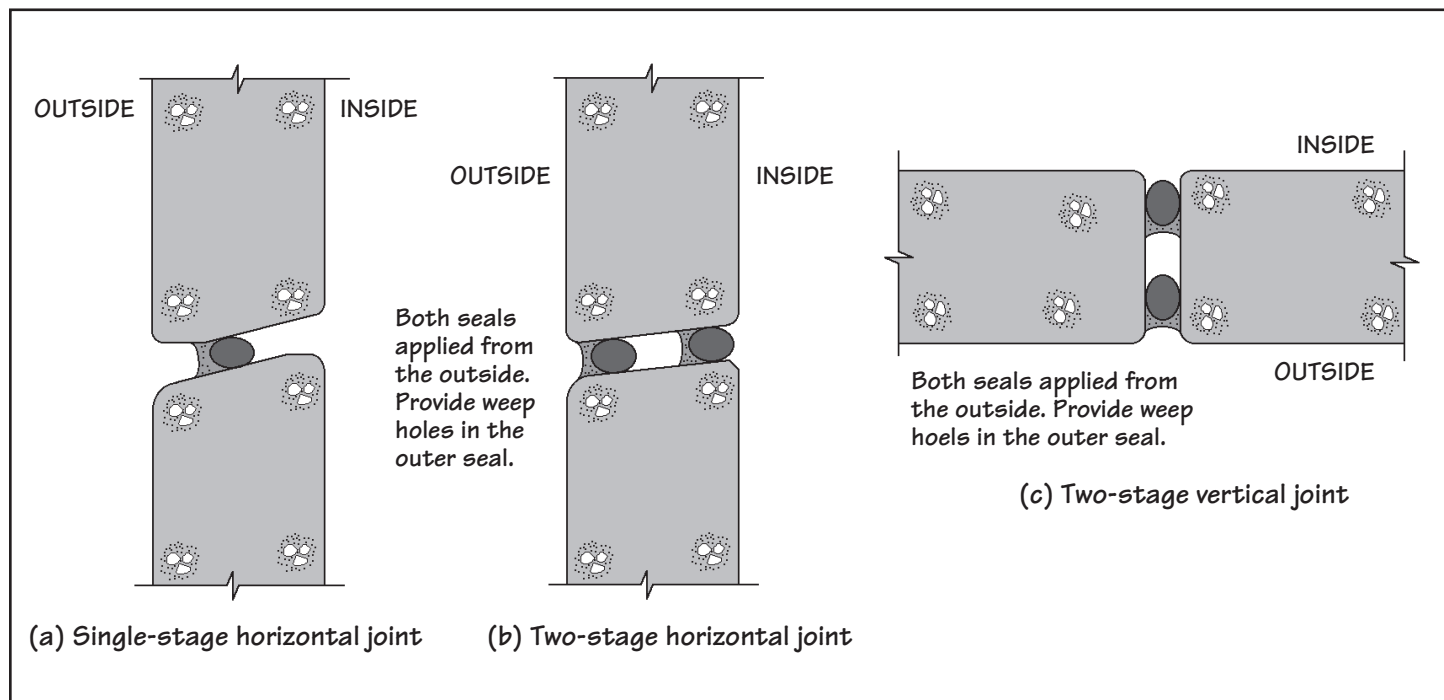

FIGURE 28.50 Treatment of joints between PC curtain wall panels.

Both inner and outer seals should be applied from the outside to avoid discontinuities at the spandrel beams and floor slabs. This requires a deep-stem roller to push the backer rod deep into the joint and a long-nozzle sealant gun.

In addition to sealed joints, PC curtain walls should be provided with stainless steel channels and weep tubes to collect and drain any condensed water that may collect on the back face of the panels (see Figure 28.49).

INSULATED, SANDWICHED PANELS

PC curtain wall panels with rigid plastic foam insulation sandwiched between two layers of concrete may be used in cold regions. A sandwich panel consists of an outer layer of concrete and an inner layer of concrete, in which both layers are connected together with ties through an intermediate layer of rigid plastic foam insulation.

The outer layer is a nonstructural layer, whereas the inner layer is designed to carry the entire load and transfer it to the structural frame. The panel is fabricated by first casting the concrete for the nonstructural layer. This is followed by embedding the ties and placing the insulation boards over the ties. The insulation is provided with holes so that the ties project above the insulation and are embedded in the concrete that is cast above the insulation.

PRACTICE QUIZ

Each question has only one correct answer. Select the choice that best answers the question.

22. The strength of concrete used in precast concrete curtain walls is generally
- greater than or equal to 3,000 psi.
 - greater than or equal to 4,000 psi.
 - greater than or equal to 5,000 psi.
 - none of the above.
23. Precast concrete curtain wall panels are generally
- cast on the construction site.
 - fabricated by a ready-mix concrete plant and transported to the construction site.
 - (a) or (b).
 - none of the above.
24. The number of bearing supports in a precast concrete curtain wall panel must be
- one.
 - two.
 - three.
 - four.
 - between three and six.
25. The structural design of precast concrete curtain wall panels is generally the responsibility of the
- structural engineer, who designs the structural frame of the building in which the panels are to be used.
 - structural engineer retained by the panel fabricator.
 - structural engineer retained by the general contractor of the building.
 - structural engineer specially retained by the owner.
 - none of the above.
26. During the erection of precast concrete curtain wall panels, the panels are leveled. The leveling of the panels is provided in the
- panels' bearing supports.
 - panels' tieback connections.
 - (a) or (b).
 - (a) and (b).

(Continued)

PRACTICE QUIZ (Continued)

27. The bricks used in brick-faced concrete curtain wall panels are generally
- of the same thickness as those used in brick veneer construction.
 - thicker than those used in brick veneer construction.
 - thinner than those used in brick veneer construction.
 - any one of the above, depending on the building.
28. A bond break such as a polyethylene sheet membrane is generally used between the concrete and bricks in a brick-faced precast concrete curtain wall panel.
- True
 - False
29. The connection between the natural stone facing and the backup concrete in a stone-faced precast concrete curtain wall panel is obtained by
- the roughness of the stone surface that is in contact with the concrete.
 - nonmoving steel dowels.
 - flexible steel dowels.
 - any one of the above.

28.10 GLASS FIBER–REINFORCED CONCRETE (GFRC) CURTAIN WALL

As the name implies, glass fiber–reinforced concrete (GFRC) is a type of concrete whose ingredients are portland cement, sand, glass fibers, and water. Glass fibers provide tensile strength to concrete. Unlike a precast concrete panel, which is reinforced with steel bars, a GFRC panel does not require steel reinforcing.

The fibers are 1 to 2 in. long, and are thoroughly mixed and randomly dispersed in the mix. The random and uniform distribution of fibers not only provides tensile strength, but also gives toughness and impact resistance to a GFRC panel. Because normal glass fibers are adversely affected by wet portland cement (due to the presence of alkalies in portland cement), the fibers used in a GFRC mix are alkali-resistant (AR) glass fibers.

GFRC SKIN AND COLD-FORMED STEEL FRAME

A GFRC curtain wall panel consists of three main components:

- GFRC skin
- Cold-formed steel backup frame
- Anchors that connect the skin to the steel backup frame

Of these three components, only the skin is made of GFRC, which is generally $\frac{1}{2}$ - to $\frac{3}{4}$ -in.-thick. The skin is anchored to a frame consisting of cold-formed (galvanized) steel members, Figure 28.51. In this combination, the GFRC skin transfers the loads to the frame, which, in turn, transfers the loads to the building's structure. The size and spacing of backup frame members depend on the overall size of the panel and the loads to which it is subjected.

FLEX ANCHORS

The skin is hung 2 in. (or more) away from the face of the frame using bar anchors. The gap between the skin and the frame is essential because it allows differential movement between the skin and the frame, particularly during the period when the fresh concrete in the skin shrinks as water evaporates.



FIGURE 28.51 (a)
The front face of a large GFRC panel after light abrasive blasting. It is being lifted for storage in the fabricator's shed.

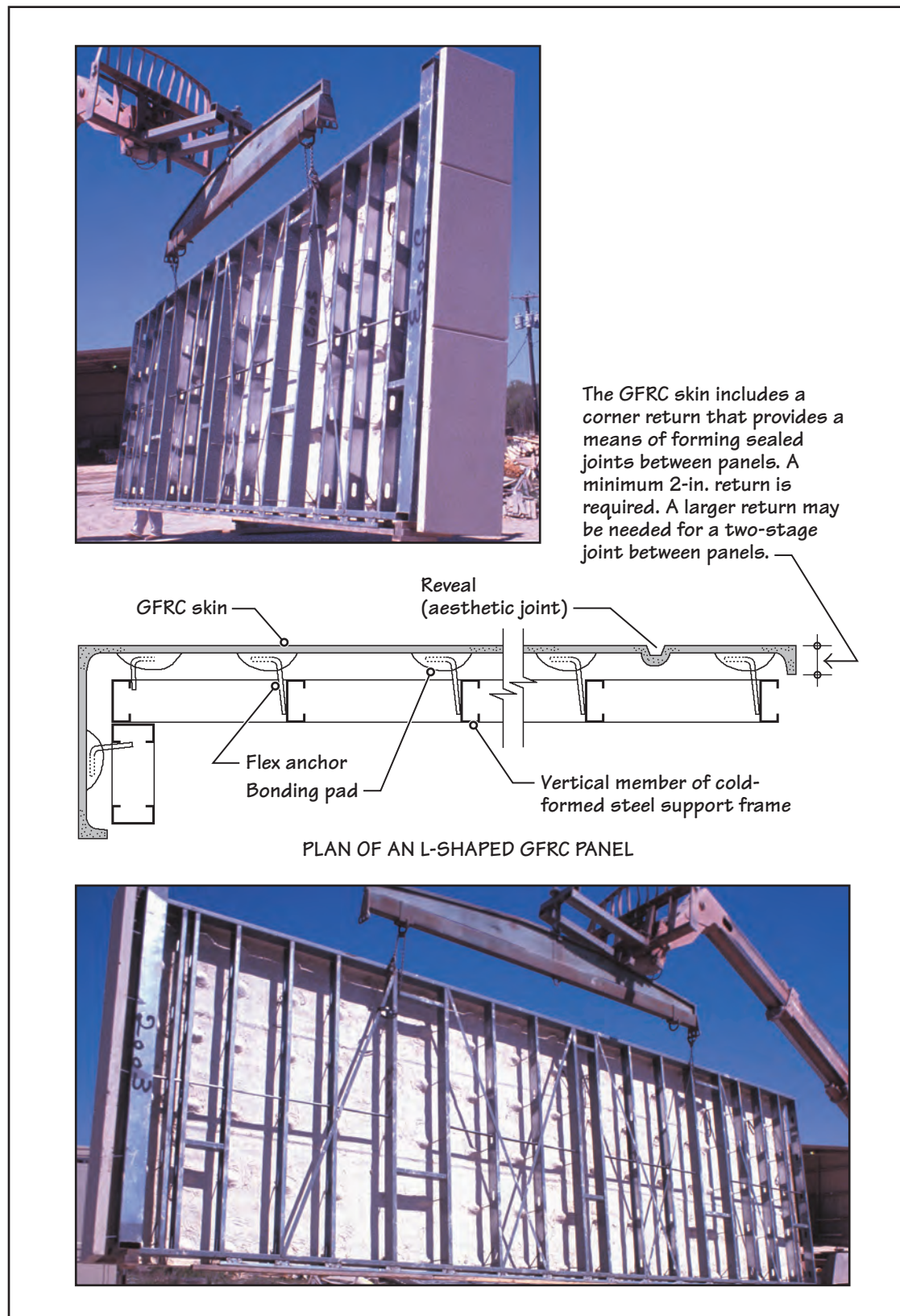

FIGURE 28.51 (b) The side and back faces of an L-shaped GFRC panel showing the supporting cold-formed steel frame.

The anchors are generally $\frac{3}{8}$ -in.-diameter steel bars bent into an L shape. To provide corrosion resistance, cadmium-plated steel is generally used for the anchors. One end of an anchor is welded to the frame, and the other end is embedded in the skin. The skin is thickened around the anchor embedment. The thickened portion of the skin is referred to as a *bonding pad*, Figure 28.52.

The purpose of the anchors is to transfer both gravity and lateral loads from the skin to the frame. In doing so, the anchors must be fairly rigid in the plane perpendicular to the panel; that is, they should be able to transfer the loads without any deformation in the anchors.

However, the skin will experience in-plane dimensional changes due to moisture and temperature effects. The anchor must, therefore, have sufficient flexibility to allow these changes to occur without excessively stressing the skin. One way of achieving this goal is to flare the anchor away from the frame and weld it to the frame member at the far end, Figure 28.53. The term *flex anchor* underscores the importance of anchor flexibility.

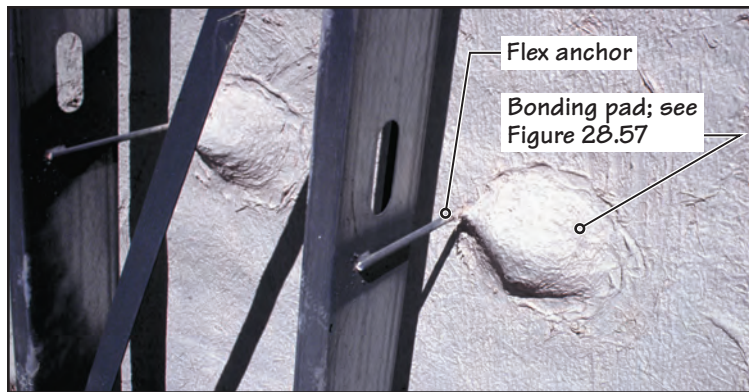

FIGURE 28.52 Bonding pads and flex anchors.

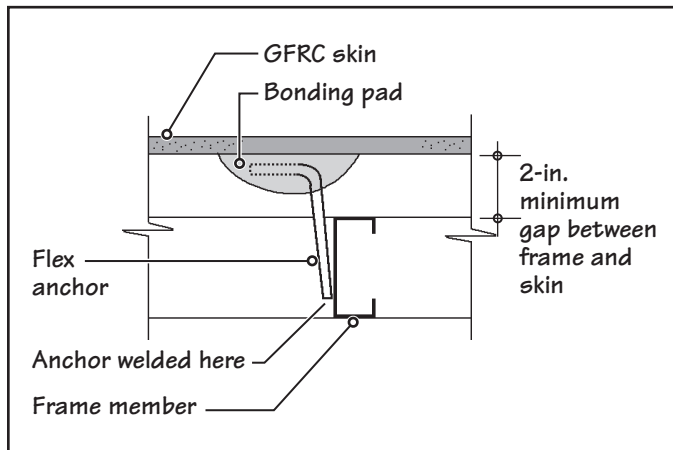

FIGURE 28.53 Flex anchor detail highlighting the flexibility of a flex anchor.

PANEL SHAPES

Like the precast concrete curtain wall panels, GFRc curtain wall panels can be formed into different shapes, depending on the building's facade. The most commonly used panels are floor-to-floor panels (Figure 28.51), window wall panels, and spandrel panels, similar to PC curtain wall panels. A spandrel panel is essentially a solid panel of smaller height than a floor-to-floor panel. Because the panels can be configured in several ways for a given facade, the architect must work with the GFRc fabricator before finalizing the panel shapes.

28.11 FABRICATION OF GFRc PANELS

Figures 28.54 to 28.57 show the six-step process of fabricating a GFRc panel.

- *Preparing the Mold:* The mold must be fabricated to the required shape, Figure 28.54(a). The mold generally consists of plywood, but other materials, such as steel or plastics, may be used. A form-release compound is applied to the mold before applying the GFRc mix to facilitate the panel's removal from the mold.
- *Applying the Mist Coat:* Before GFRc mix is sprayed on the panel, a thin cement-sand slurry coat, referred to as a *mist coat*, is sprayed on the mold, Figure 28.54(b). Because the mist coat does not contain any glass fibers, it gives a smooth, even surface to the panel. The thickness of the mist coat is a function of the finish the panel face is to receive. If the panel face is to be lightly abrasive-blasted, a $\frac{1}{8}$ -in.-thick mist coat is adequate.
- *Applying the GFRc Mix:* Soon after the mist coat is applied, the GFRc mix is sprayed on the mold, Figure 28.55(a). The GFRc mix consists of (white) portland cement and sand slurry mixed with about 5% (by weight) of glass fibers. Because air may be trapped in the mix during spraying, the mix is consolidated after completion of the spray application by rolling, tamping, or troweling, Figure 28.55(b).
- *Frame Placement:* After the GFRc spray is completed, a cold-formed steel support frame is placed against the skin, leaving the required distance between the skin and the frame, Figure 28.56.
- *Bonding Pads:* Finally, bonding pads are formed at each anchor using the same mix as that used for the skin, Figure 28.57.
- *Removing the Panel from the Mold and Curing:* The panel (skin and frame) is generally removed from the mold 24 h after casting and subsequently cured for a number of

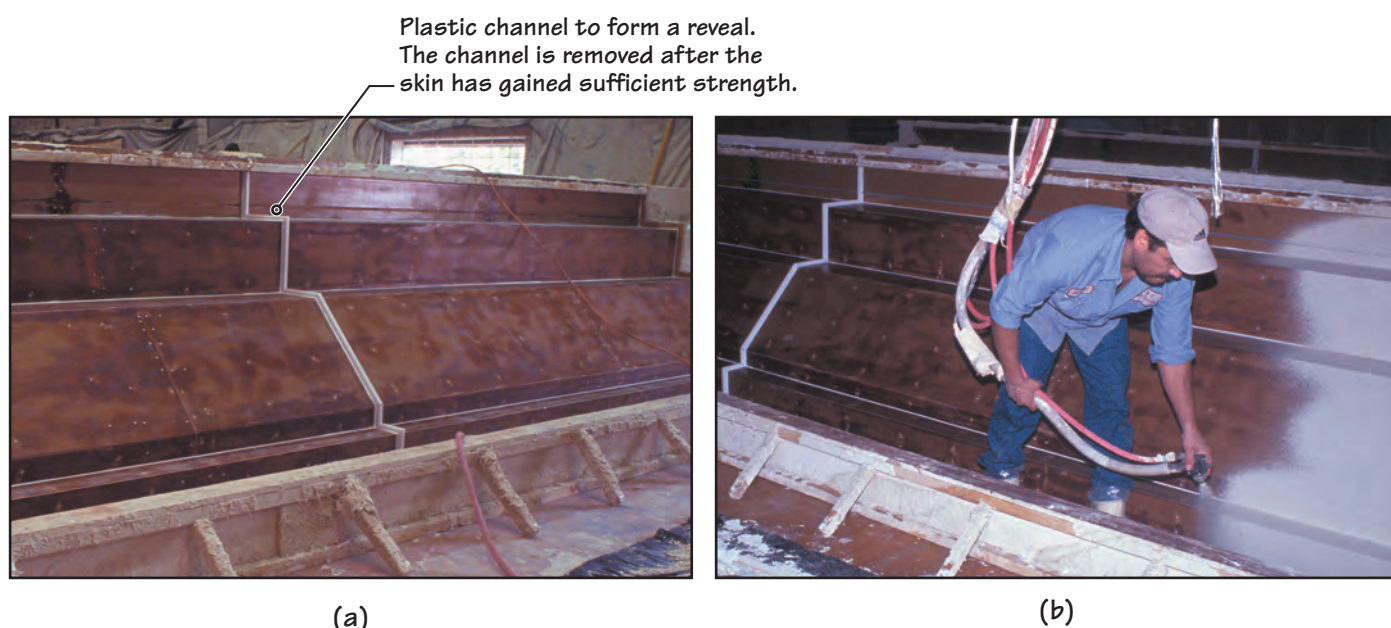

FIGURE 28.54 (a) The mold of a roof cornice GFRc panel. (b) Application of a mist coat on the mold.



FIGURE 28.55 (a) Spraying of a GFRC mix over the mist coat. (b) Consolidating the GFRC mix using a roller around the bends, edges, and corners.

days. Because the panel has not yet gained sufficient strength, special care is needed during its removal.

SURFACE FINISHES ON GFRC PANELS

The standard finish on a GFRC panel is a light abrasive-blasted finish to remove the smoothness of the surface obtained from the mist coat. However, a GFRC panel can also be given an exposed aggregate finish, which results in a surface similar to that of a precast concrete panel.

To obtain an exposed aggregate finish, the mist coat is replaced by a concrete layer, referred to as a *face mix*. The thickness of the face mix is about $\frac{3}{8}$ in., and the aggregate used in the face mix is between $\frac{3}{16}$ in. and $\frac{1}{4}$ in. The exposure of aggregate is obtained by abrasive blasting or acid etching.



FIGURE 28.56 After spraying and consolidating the mix for the GFRC skin on the mold, a cold-formed steel supporting frame is placed against the mold and bonding pads are formed.



FIGURE 28.57 Making a bonding pad (also see Figures 28.52 and 28.53).

28.12 DETAILING A GFRC CURTAIN WALL

A GFRC panel is connected to the building's structure in a system similar to that of a precast concrete panel. In other words, a GFRC panel requires two bearing connections and two or more tieback connections. However, because GFRC panels are much lighter than the precast concrete panels, their connection hardware is lighter.

As with precast concrete curtain walls, the structural design of panels and their support connections is generally the responsibility of the panel fabricator. Figures 28.58 and 28.59 show two alternative schematics for the connection of a GFRC spandrel panel to the building's structure.

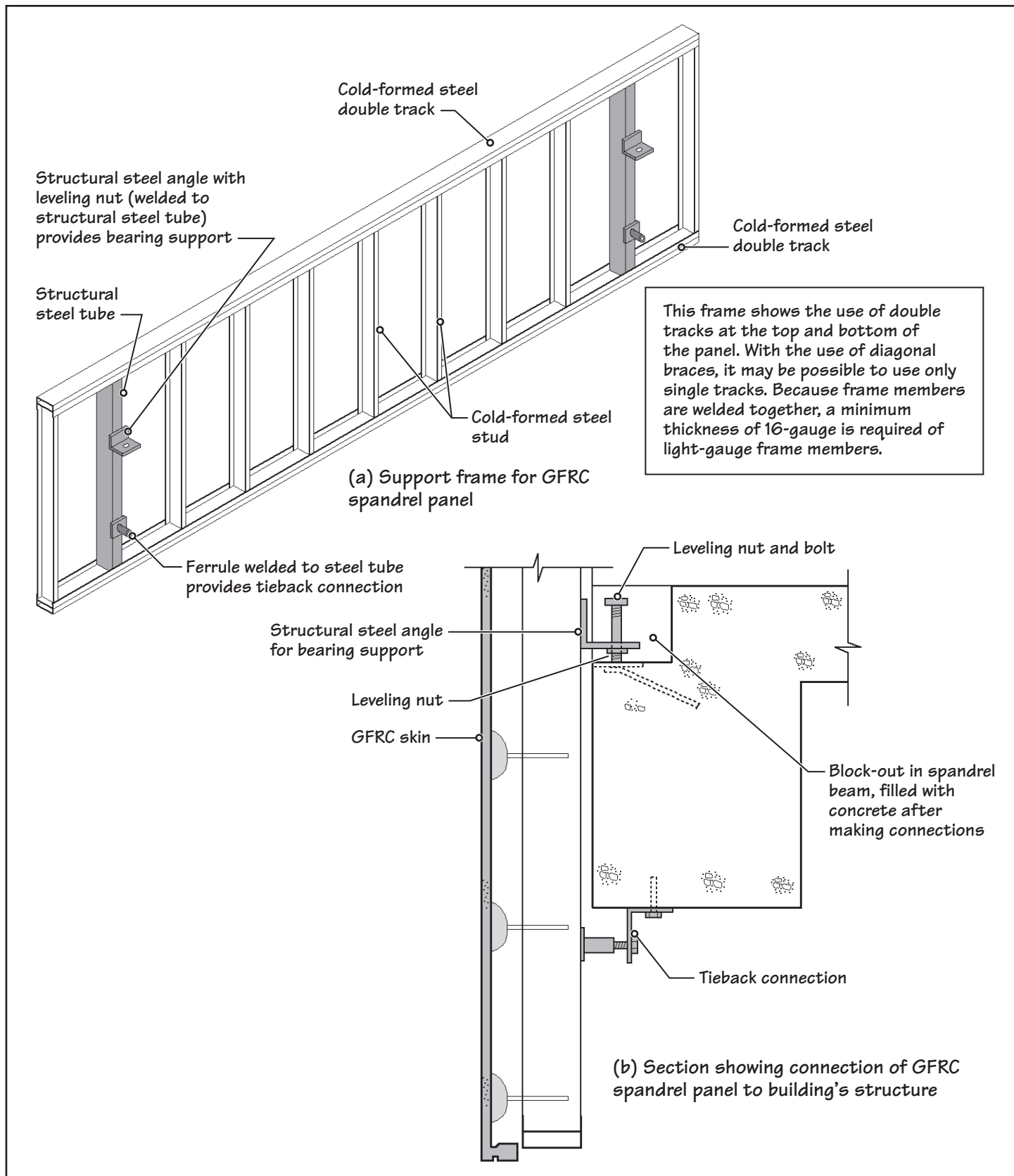

FIGURE 28.58 Schematic details of bearing and tieback connections in a GFRC spandrel panel (also see Figures 28.59 and 28.60).

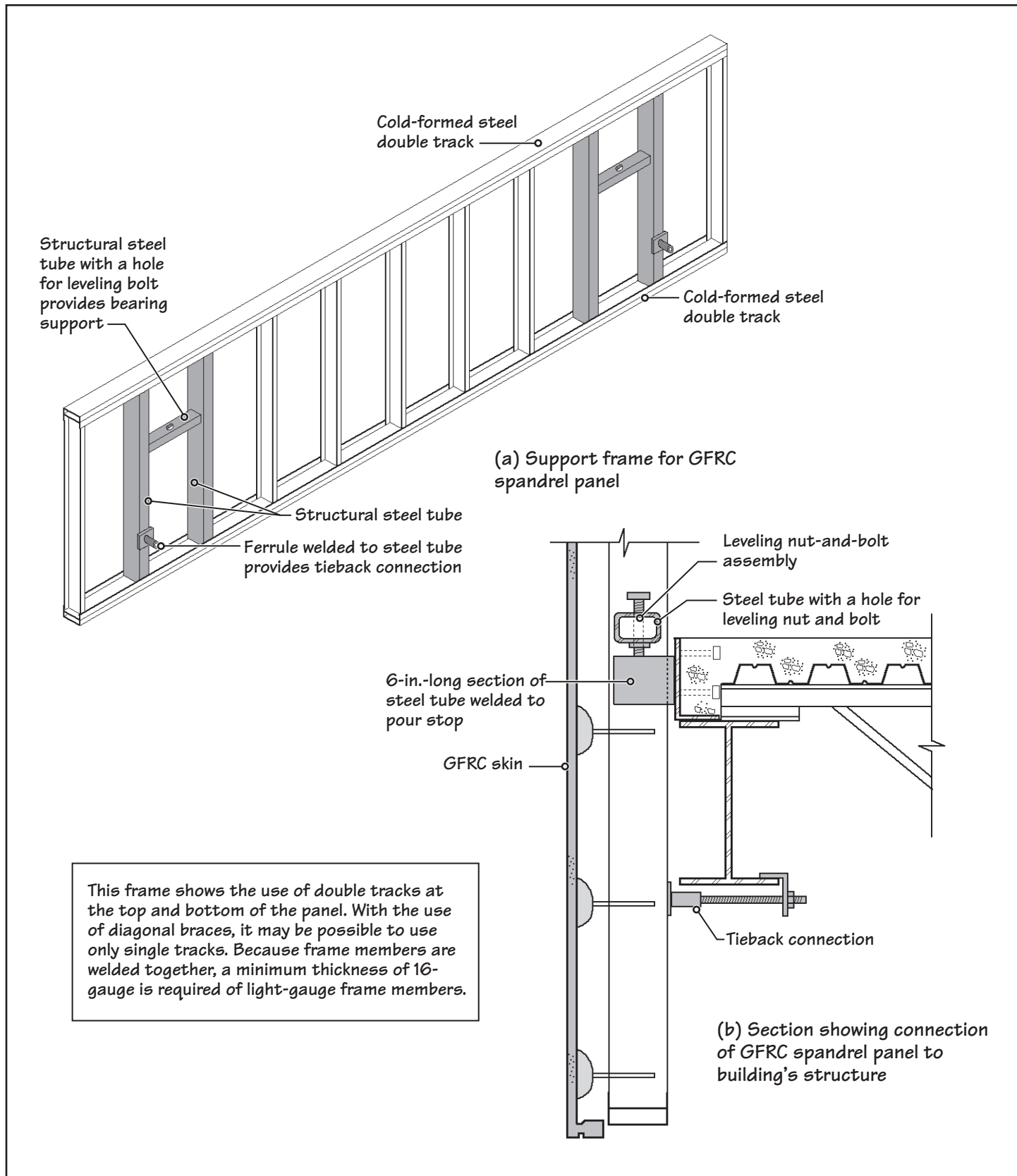

FIGURE 28.59 Schematic details of bearing supports and tieback connections in a spandrel GFRP panel (also see Figures 28.58 and 28.60).

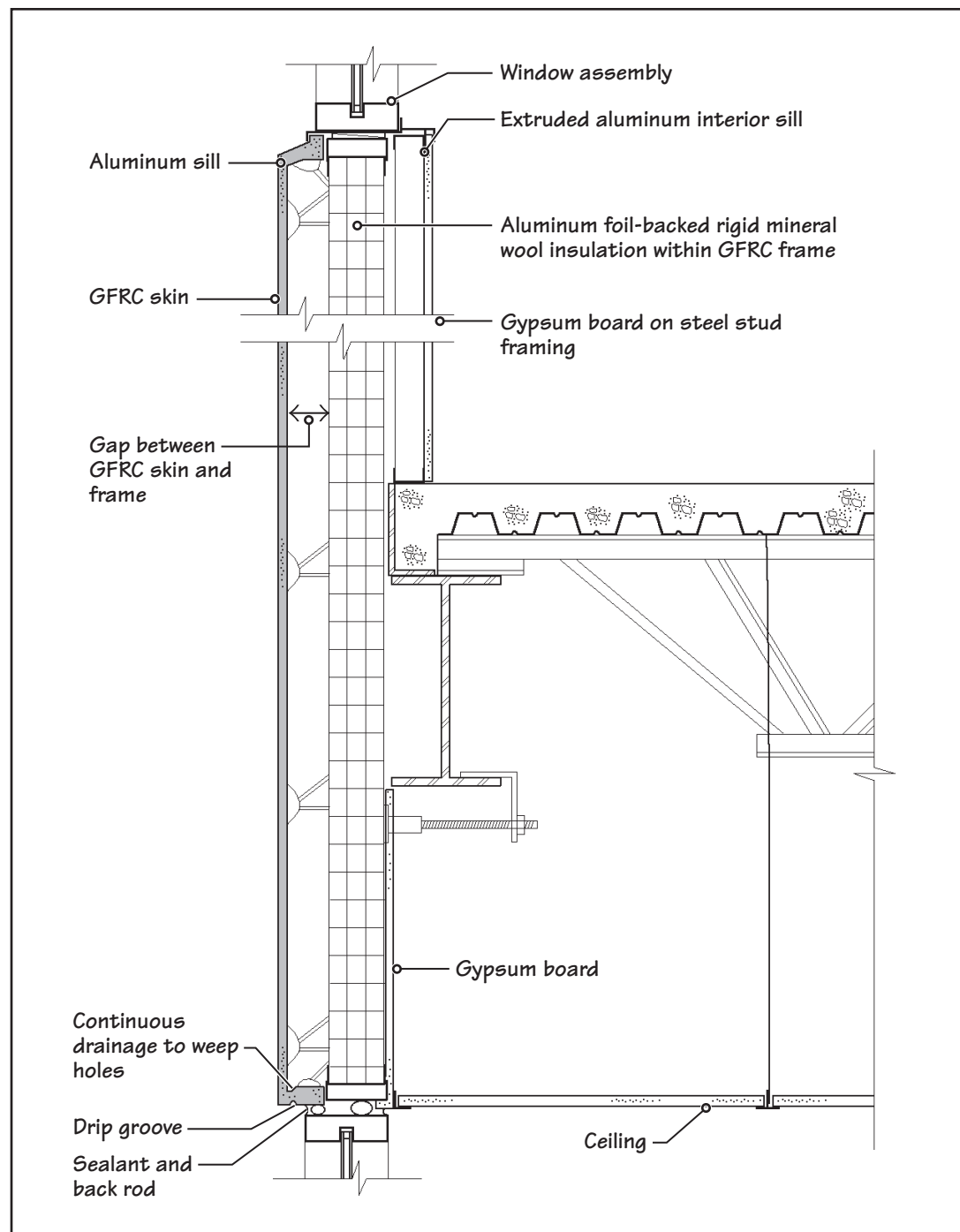

FIGURE 28.60 Schematic detail of an exterior wall with GFRc spandrel panels and ribbon windows.

Figure 28.60 shows a typical GFRc curtain wall detail. Because the GFRc skin is thin, some form of water drainage system from behind the skin should be incorporated in the panels. Additionally, the space between the GFRc skin and the panel frame should be freely ventilated to prevent the condensation of water vapor. This is generally not a requirement in precast concrete curtain walls. A two-way joint sealant system may be used at panel junctions similar to that for PC curtain walls (Figure 28.50).

PRACTICE QUIZ

Each question has only one correct answer. Select the choice that best answers the question.

30. The term *GFRc* is an acronym for
- glass fiber-reinforced concrete.
 - glass fiber-reinforced cement.
 - glass fiber-restrained concrete.
 - glass fiber-restrained cement.
 - none of the above.
31. A GFRc curtain wall panel consists of
- a GFRc skin.
 - a cold-formed steel frame.
 - anchors.
 - all of the above.
 - (a) and (b).
32. The GFRc skin is typically
- 2 to 3 in. thick.
 - $1\frac{1}{2}$ to $2\frac{1}{2}$ in. thick.
 - 1 to 2 in. thick.
 - $\frac{1}{2}$ to $\frac{3}{4}$ in. thick.
 - none of the above.

PRACTICE QUIZ (Continued)

33. The glass fibers used in the GFRC skin are referred to as *AR fibers*. The term *AR* is an acronym for
- alkali resistant.
 - acid resistant.
 - alumina resistant.
 - aluminum reinforced.
 - none of the above.
34. The anchors used in GFRC panels are typically
- two-piece anchors.
 - one-piece anchors.
 - either (a) or (b), depending on the thickness of the GFRC skin.
 - either (a) or (b), depending on the lateral loads to which the panel is subjected.
 - none of the above.
35. The GFRC skin is obtained by
- casting the GFRC mix in a mold similar to casting a precast concrete member.
 - applying the mix with a trowel.
 - spraying the mix over a mold.
 - any of the above, depending on the panel fabricator.
36. GFRC curtain wall panels are generally lighter than the corresponding precast concrete curtain wall panels.
- True
 - False
37. In prefabricated brick curtain wall panels, the bricks used are
- generally of the same thickness as those used in brick veneer construction.
 - generally thicker than those used in brick veneer construction.
 - generally thinner than those used in brick veneer construction.
38. Prefabricated brick curtain wall panels are generally fabricated
- in a brick-manufacturing plant.
 - in a masonry contractor's fabrication yard.
 - in a precast concrete fabricator's plant.
 - at the construction site.

REVIEW QUESTIONS

- Using sketches and notes, explain the adjustability requirements of anchors used in a brick veneer wall assembly.
- Using sketches and notes, explain the functions of a shelf angle and a lintel angle in a brick veneer assembly.
- With the help of sketches and notes, explain various ways in which weep holes can be provided in a brick veneer assembly.
- Discuss the pros and cons of using a CMU backup wall versus a steel stud backup wall in a brick veneer wall assembly.
- With the help of sketches and notes, explain the support system of a precast concrete curtain wall panel.
- Using sketches, explain the commonly used shapes of precast concrete wall panels.
- With the help of a sketch, explain the two-stage joint seal in precast concrete wall panels. What are its advantages over a single-stage joint seal?
- Using a sketch, explain the purpose of a (a) bonding pad and (b) flex anchor in a GFRC panel.